

Foundations of Control and Estimation Over Lossy Networks

Mathematical tools are proposed for optimal design of networked control systems when physical link losses limit available information.

By LUCA SCHENATO, *Member IEEE*, BRUNO SINOPOLI, *Member IEEE*,
MASSIMO FRANCESCHETTI, *Member IEEE*, KAMESHWAR POOLLA, AND
S. SHANKAR SASTRY, *Fellow IEEE*

ABSTRACT | This paper considers control and estimation problems where the sensor signals and the actuator signals are transmitted to various subsystems over a network. In contrast to traditional control and estimation problems, here the observation and control packets may be lost or delayed. The unreliability of the underlying communication network is modeled stochastically by assigning probabilities to the successful transmission of packets. This requires a novel theory which generalizes classical control/estimation paradigms. The paper offers the foundations of such a novel theory.

The central contribution is to characterize the impact of the network reliability on the performance of the feedback loop. Specifically, it is shown that for network protocols where successful transmissions of packets is acknowledged at the receiver (e.g., TCP-like protocols), there exists a critical threshold of network reliability (i.e., critical probabilities for the successful delivery of packets), below which the optimal controller fails to stabilize the system. Further, for these protocols, the separation principle holds and the optimal LQG controller is a linear function of the estimated state. In stark contrast, it is shown that when there is no acknowledgement of successful delivery of control packets (e.g., UDP-like protocols),

the LQG optimal controller is in general nonlinear. Consequently, the separation principle does not hold in this circumstance.

KEYWORDS | LQG control; networked control systems; optimal estimation; packet drop; separation principle; stability; TCP; UDP

I. INTRODUCTION

The rapid convergence of sensing, computing and wireless communication technologies on cost effective, low power, miniature devices, is enabling a host of new control applications. In recent years, we have witnessed wireless technologies replacing wired counterparts in all applications where it can be securely and reliably implemented. Particularly notable is the case of cellular telephony, that is rapidly driving wireline telephony to obsolescence. Similarly, LAN access is now dominated by WI-FI. The next dominos to fall are likely to be wired broadband access technologies such as DSL, which will be replaced by WiMax and 3G wireless data services.

In recent years, sensor technology has witnessed extraordinary growth. Everything is getting “sensed:” vehicles, roads, buildings, airspaces, and the environment. Sensors are getting smaller, cheaper, pervasive, and more powerful. The confluence of sensing technology and wireless communication will spawn a plethora of new technological opportunities. Indeed, the ability to inexpensively gather data over a network at a very fine temporal and spatial granularity, and the ability to process this data in real-time and then perform appropriate control actions, is enabling the development of a number of new applications [1]–[3]. The possibilities created by wireless sensor networks are extraordinary. These include real time alarm systems for catastrophic, yet predictable events, such as tsunamis, landslides, and rail accidents. Another potential

Manuscript received August 8, 2005; revised July 28, 2006. This work was supported in part by DARPA under Grant F33615-01-C-1895, in part by the National Science Foundation (NSF) under CAREER Award CNS-0546235, in part by the European Community Research Information Society Technologies under Grant RECSYS IST-2001-32515, and under Marie Curie International Reintegration Grant SENSNET-MIRG-6-CT-2005-014815.

L. Schenato is with the Department of Information Engineering, University of Padova, 35100 Padova, Italy (e-mail: schenato@dei.unipd.it).

B. Sinopoli, K. Poolla, and S. Sastry are with the Department of Electrical Engineering, the University of California at Berkeley, Berkeley, CA 94720-1770 USA (e-mail: sinopoli@eecs.berkeley.edu; poolla@eecs.berkeley.edu; sastry@eecs.berkeley.edu).

M. Franceschetti is with the Department of Electrical and Computer Engineering, the University of California at San Diego, La Jolla, CA 92093-0407 USA (e-mail: massimo@ece.ucsd.edu).

Digital Object Identifier: 10.1109/JPROC.2006.887306

application is using sensor networks to efficiently and reliably control electric power grids by exchanging load information between local stations and optimizing power delivery while avoiding costly and dangerous blackouts. Realizing the promise of sensor network technologies requires the development of theoretical foundations of remote control over unreliable networks. This will enable the evolution of design rules, the navigation of performance-complexity tradeoffs, and the systematic design of sensor networks for various target applications.

The benefits of pervasive networking and sensing are compelling. For example buildings, both residential and commercial, can greatly benefit from the use of sensor networks, by decreasing construction and operating costs, while improving comfort and safety. Today, installation (and particularly wiring) accounts for more than half of the cost of an Heating, Ventilation, Air Conditioning (HVAC) system in a building. Wireless communication could sensibly lower this cost [4], [5]. Moreover, combining wireless technology with Micro Electro Mechanical Systems (MEMS) technology could further lower cost, allowing sensors to be embedded in products such as ceiling tiles and furniture, and enable improved control of the indoor environment [6]. These sensor networks could dramatically improve energy efficiency in buildings.

Another example where sensor networks technology is anticipated to have a significant impact is Supervisory Control And Data Acquisition (SCADA) networks [7], [8]. These networks, were originally developed in the 1960s, and are used for industrial measurement, monitoring, and control systems, especially by electricity and natural gas utilities, water and sewage utilities, railroads, telecommunications, and other critical infrastructure components. They enable remote monitoring and control of a large variety of industrial devices, such as water and gas pumps, track switches, and traffic signals.

SCADA systems typically implement a distributed system whose elements are called points. A point can be a single input or output value, monitored or controlled by the system. A variety of host computers allow for “supervisory level” control of the remote site. The majority of the control decisions take place at distributed locations called Remote Terminal Units (RTUs). RTUs connect to physical equipment such as switches, pumps and other devices, and monitor and control these devices. SCADA systems often have Distributed Control System (DCS) components. In this case smart RTUs are employed, capable of performing autonomous control and decision without the intervention of the master computers. The role of host computers is generally restricted to supervisory level control. Data acquisition begins at the RTU level and includes meter readings and equipment statuses that are communicated to the SCADA as required. Data is then compiled and formatted so that a control room operator using the SCADA system can cogently make appropriate supervisory decisions that may require over-riding normal RTU controls.

SCADA systems have traditionally used combinations of various infrastructure technologies to meet communication requirements. The existence of a consolidated wired legacy infrastructure has impeded the development of open systems based on wireless technology. Wireless technology could provide superior performance and lower costs, with simpler maintenance and upgradability. Most of the remote monitoring and control application could run over the wireless infrastructure, while components could be easily swapped without any service interruption.

A third example of application of sensor networks technology is automotive vehicle networks. Electronics is quickly becoming a primary differentiator in the automotive industry, with vendors offering electronic services such as Global Positioning System (GPS), in-vehicle safety and security system, DVD, and drive-by-wire systems [9]. Electronic systems now account for a sizeable part of the cost and weight of a vehicle. Cars have over 50 embedded computers running a variety of applications, from safety-critical to pure entertainment. These applications typically consist of sensors, actuators, and controllers that are spatially distributed in the vehicle. These components communicate using dedicated wires, bringing the length of wires in high-end luxury cars to amount for more than three miles and adding over two hundred pounds of weight to the vehicle [10]. As the need for electronics is likely to increase with new services and applications, this wireline design scheme is unsustainable. In-vehicle networking will become essential and a prime application of networked embedded systems theory. As many applications converge in sharing computing and communication resources, issues of scheduling, network delay and data loss will need to be dealt with systematically.

In examining the applications detailed above, a common pattern emerges. Data is sent from possibly multiple sensors to one or more computing units, using a communication network. Such data are then processed to estimate the state of a dynamical system, and actuator signals are sent to actuators using the same network. Both measurements and actuator signals have very stringent timing constraints that the network needs to be able to meet. The presence of a communication network in the feedback control loop raises a number of issues. One of the key parameters in digital control systems design is the selection of a fixed sampling period. This is mainly a function of the system dynamics, and it places a hard constraint on the time necessary to receive observations, estimate the state, compute the subsequent control inputs, and transmit these to the actuators. All of this needs to happen within a single sampling interval. The computing power of modern processors combined with wired, dedicated interconnections between various subsystems usually guarantees that such constraints are met. In designing feedback control systems around wireless sensor networks, the implicit assumption of data availability no longer holds, as data packets are randomly dropped and

delayed. While classical control theories provide a wealth of analytical results, they critically rely on the assumption that the underlying communication technology is ideal. In the wireless communication setting, neglecting nonidealities such as packet loss can result in catastrophic closed-loop performance.

This paper attempts to lay the theoretical foundations for estimation and control system design problems while explicitly accounting for realities of the underlying wireless communication network.

II. CONTROL OVER NETWORKS

A. Foundations

Wireless networks are inherently less reliable and secure than their wired counterparts. These two factors limit the penetration of wireless technology in many application contexts. For example, car manufacturers are reluctant to deploy wireless networks in cars, especially for connecting safety-critical systems such as braking and steering. Loss of data may have a disastrous effect on the behavior of the vehicle. Similarly, in SCADA systems, which represent the standard control infrastructure in industrial processes and also in some experimental facilities such as nuclear fusion, communication is ethernet based, and it is likely to remain so until we can guarantee acceptable performance and security. In short, applications need to be designed robust to unreliability in the network.

Issues of communication delay, data loss, and time-synchronization play critical roles. In particular, communication and control are tightly coupled and they cannot be addressed independently. Specific questions that arise are the following. What is the amount of data loss that the control loop can tolerate while reliably performing its task? Can communication protocols be designed to satisfy this constraint? The goal of this paper is to provide some first steps in answering such questions by examining the basic system-theoretic implications of using unreliable networks for control. This requires a generalization of classical control techniques that explicitly takes into account the stochastic nature of the communication channel.

We begin by addressing some simple canonical problems that will shed some light on the real system behavior. We shall consider the following abstractions. Packet networks communication channels typically use one of two fundamentally different protocols: TCP-like or UDP-like. In the first case there is acknowledgement of received packets, while in the second case no-feedback is provided on the communication link. The well known Transmission Control (TCP) and User Datagram (UDP) protocols used in the Internet are specific examples of our more general notion of TCP-like and UDP-like communication protocol classes. We want to study the effect of data

losses due to the unreliability of the network links under these two general protocol abstractions. Accordingly, we model the arrival of both observations and control packets as random processes whose parameters are related to the characteristics of the communication channel. Two independent Bernoulli processes are considered, with parameters $\bar{\gamma}$ and $\bar{\nu}$, that govern packet losses between the sensors and the estimation-control unit, and between the latter and the actuation points, see Fig. 1. We remark that using Bernoulli processes is clearly an idealization that is chosen for mathematical tractability. The networking component obviously has an additional impact on the performance of the closed loop systems. Routing and congestion control mechanisms would affect the packet arrival probability and it is necessary in practice to estimate this probability to compute the optimal control law. The presence of correlations in the packet loss process can be taken into account, in principle, at the cost of complicating the mathematical analysis. Our foundations are instead based on simple abstractions which, as we shall see, reveal useful design guidelines and can explain real system behaviors that are observed in practice.

B. Previous Work

Study of stability of dynamical systems where components are connected asynchronously via communication channels has received considerable attention in the past few years and our contribution can be put in the context of the previous literature. In [11] and [12], the authors proposed to place an estimator, i.e., a Kalman filter, at the sensor side of the link without assuming any statistical model for the data loss process. In [13], Smith *et al.* considered a suboptimal but computationally efficient estimator that can be applied when the arrival process is modeled as a Markov chain, which is more general than a Bernoulli process. Other works include Nilsson *et al.* [14], [15] who present the LQG optimal regulator with bounded delays between sensors and controller, and between the controller and the actuator. In this work, bounds for the critical probability values are not provided and there is no analytic solution for the optimal controller. The case where dropped measurements are replaced by zeros is considered by Hadjicostis and Touri [16], but only in the scalar case. Other approaches include using the last received sample for control [15], or designing a dropout compensator [17], which combines estimation and control in a single process. However, the former approach does not consider optimal control and the latter is limited to scalar systems. Yu *et al.* [18] studied the design of an optimal controller with a single control channel and deterministic dropout rates. Seiler *et al.* [19] considered Bernoulli packet losses only between the plant and the controller and posed the controller design as an H_∞ optimization problem. Other authors [20]–[23] model networked control systems with missing packets as Markovian jump linear systems (MJLSs), however this

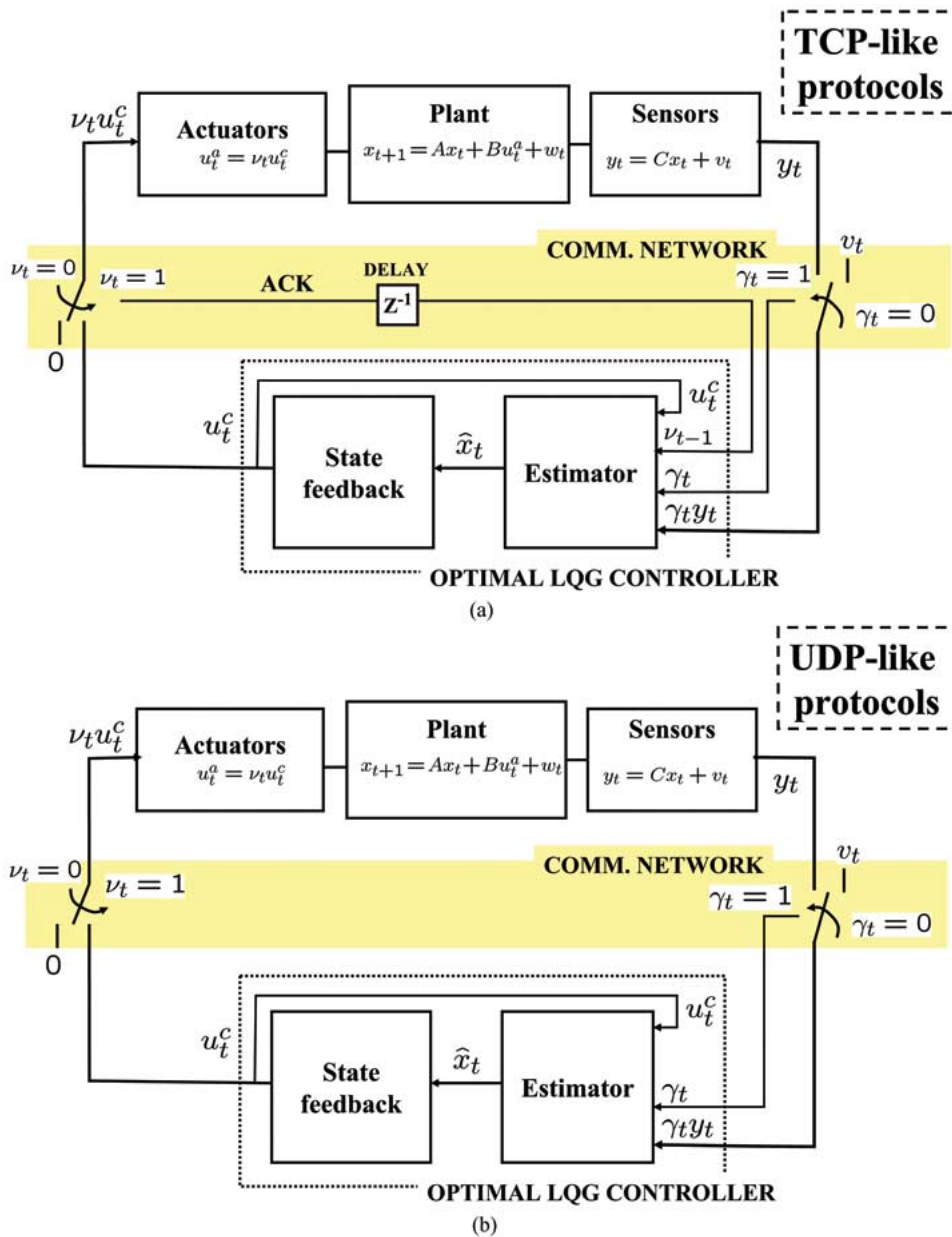

Fig. 1. Architecture of the closed loop system over a communication network under TCP-like protocols (top) and UDP-like protocols (bottom). The binary random variables ν_t and γ_t indicates whether packets are transmitted successfully.

approach gives suboptimal controllers since the estimators are stationary. Finally, Elia [24], [25] proposed to model the plant and the controller as deterministic time invariant discrete-time systems connected to zero-mean stochastic structured uncertainty. The variance of the stochastic perturbation is a function of the Bernoulli parameters, and the controller design is posed as an optimization problem to maximize mean-square stability of the closed loop system. This approach allows analysis of Multiple Input Multiple Output (MIMO) systems with many different controller and receiver compensation schemes [24],

however, it does not include process and observation noise and the controller is restricted to be time-invariant, hence suboptimal. There is also an extensive literature, inspired by Shannon's results on the maximum bit-rate that a channel with noise can reliably carry, whose goal is to determine the minimum bit-rate that is needed to stabilize a system through feedback [26]–[35]. This approach is somewhat different from ours as we consider bits to be grouped into packets that form single entities which can be lost. Nonetheless there are several similarities that are not yet fully explored.

Compared to previous works, this paper considers the alternative approach where the external compensator feeding the controller is the optimal time varying Kalman gain. Moreover, this paper considers the general Multiple Input Multiple Output (MIMO) case, and gives some necessary and sufficient conditions for closed loop stability. The work of [36] is most closely related to this paper. However, we consider the more general case when the matrix C is not the identity and there is noise in the observation and in the process. In addition, we also give stronger necessary and sufficient conditions for existence of the solution in the infinite horizon LQG control.

C. Our Contribution

We study the effect of data losses due to the unreliability of the network links under two different classes of protocols. In our analysis, the distinction between the two classes of protocols will reside exclusively in the availability of packet acknowledgement. Adopting the framework proposed by Imer et al. [36], we will refer, therefore, to TCP-like protocols if packet acknowledgement is available and to UDP-like protocols otherwise.

We show that, for the TCP-like case, the classic separation principle holds, and consequently the controller and estimator can be designed independently. Moreover, the optimal controller is a linear function of the state. In sharp contrast, for the UDP-like case, a counter-example demonstrates that the optimal controller is in general nonlinear. In the special case when the state is fully observable and the observation noise is zero, the optimal controller is indeed linear. We explicitly note that a similar, but slightly less general special case was previously analyzed in [36], where both observation and process noise are assumed to be zero and the input coefficient matrix to be invertible.

Our final set of results relate to convergence in the infinite horizon. Here, results on estimation with missing observation packets [37], [38] are extended to the control case. We show the existence of a critical domain of values for the parameters of the Bernoulli arrival processes, $\bar{\nu}$ and $\bar{\gamma}$, outside which a transition to instability occurs and the optimal controller fails to stabilize the system.

These results are visually summarized in Fig. 2, where our stability bounds are depicted for a scalar system. The stability regions are the regions above those bounds. Notice that for TCP-like protocols there exist critical arrival probabilities for the control and observation packets below which the system is in the unstable region. These critical values are independent of each other, which is another consequence of the fact that the separation principle holds for these protocols.

In contrast, for UDP-like protocols the critical arrival probabilities for the control and observation channels are coupled, and the stability domain boundary assumes a curved form. The performance of the optimal controller degrades considerably when compared to TCP-like proto-

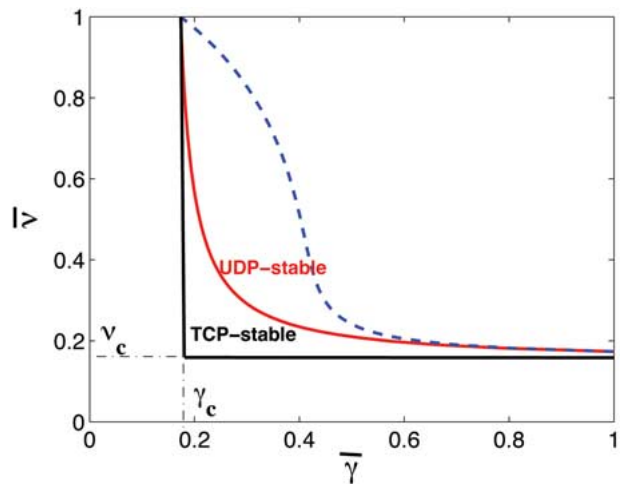

Fig. 2. Stability regions for TCP-like protocols and UDP-like protocols for a scalar unstable system. These bounds are tight (i.e., necessary and sufficient) in the scalar case. The dashed line corresponds to the boundary of a weaker (sufficient) condition on the stability region for UDP-like protocols as recently reported in [36].

cols, as the stability region of UDP is strictly contained into the one of TCP. Finally, the figure also reports the boundary of a weaker condition on the stability region for UDP-like protocols as reported in [36], which is indicated with a dashed line.

III. PROBLEM FORMULATION

Consider the following linear stochastic system with intermittent observation and control packets:

$$x_{k+1} = Ax_k + Bu_k^a + w_k \quad (1)$$

$$u_k^a = \nu_k u_k^c \quad (2)$$

$$y_k = \gamma_k Cx_k + v_k \quad (3)$$

where u_k^a is the control input to the actuator, u_k^c is the desired control input computed by the controller, (x_0, w_k, v_k) are Gaussian, uncorrelated, white, with mean $(\bar{x}_0, 0, 0)$ and covariance (P_0, Q, R) respectively, and (γ_k, ν_k) are i.i.d. Bernoulli random variables with $P(\gamma_k = 1) = \bar{\gamma}$ and $P(\nu_k = 1) = \bar{\nu}$. The stochastic variable ν_k models the packet loss between the controller and the actuator: if the packet is correctly delivered then $u_k^a = u_k^c$, otherwise if it is lost then the actuator does nothing, i.e., $u_k^a = 0$. This compensation scheme is summarized by (2). This modeling choice is not unique: for example if the control packet u_k^c is lost, the actuator could employ the previous control value, i.e., $u_k^a = u_{k-1}^a$, as suggested in [15]. The analysis of this scheme requires a different problem

formulation and is not considered here. However, both schemes are natural compensation methods for input packet loss, and in Section VII an empirical comparison seems to suggest that the zero-input scheme indeed outperforms the hold-input scheme. The stochastic variable γ_k models the packet loss between the sensor and the controller: if the packet is delivered then $y_k = Cx_k + v_k$, while if the packet is lost the controller reads pure noise, i.e., $y_k = v_k$. This observation model is summarized by (3). A different observation formalism was proposed in [37], where the missing observation was modeled as an observation for which the measurement noise had infinite covariance. It is possible to show that both models are equivalent, but the one considered in this paper has the advantage of simplifying the equations. This is because at times when packets are not delivered, the optimal estimator ignores the observation y_k , therefore, its value is irrelevant.

Let us define the following information sets:

$$\mathcal{I}_k = \begin{cases} \mathcal{F}_k \triangleq \{\mathbf{y}^k, \boldsymbol{\gamma}^k, \boldsymbol{\nu}^{k-1}\}, & \text{TCP-like} \\ \mathcal{G}_k \triangleq \{\mathbf{y}^k, \boldsymbol{\gamma}^k\}, & \text{UDP-like} \end{cases} \quad (4)$$

where $\mathbf{y}^k = (y_k, y_{k-1}, \dots, y_1)$, $\boldsymbol{\gamma}^k = (\gamma_k, \gamma_{k-1}, \dots, \gamma_1)$, and $\boldsymbol{\nu}^k = (\nu_k, \nu_{k-1}, \dots, \nu_1)$.

Consider also the following cost function:

$$J_N(\mathbf{u}^{N-1}, \bar{x}_0, P_0) = \mathbb{E} \left[x'_N W_N x_N + \sum_{k=0}^{N-1} (x'_k W_k x_k + \nu_k u'_k U_k u_k) \mid \mathbf{u}^{N-1}, \bar{x}_0, P_0 \right] \quad (5)$$

where $\mathbf{u}^{N-1} = (u_{N-1}, u_{N-2}, \dots, u_1)$. Note that we are weighting the input only if it is successfully received at the plant. In the event it is not received, the plant applies zero input and, therefore, there is no energy expenditure.

We now seek a control input sequence \mathbf{u}^{*N-1} as a function of the admissible information set \mathcal{I}_k , i.e., $u_k = g_k(\mathcal{I}_k)$, that minimizes the functional defined in (5), i.e.,

$$J_N^*(\bar{x}_0, P_0) \triangleq \min_{\mathbf{u}_k = g_k(\mathcal{I}_k)} J_N(\mathbf{u}^{N-1}, \bar{x}_0, P_0) \quad (6)$$

where $\mathcal{I}_k = \{\mathcal{F}_k, \mathcal{G}_k\}$ is one of the sets defined in (4). The set \mathcal{F} corresponds to the information provided under an acknowledgement-based communication protocols (TCP-like) in which successful or unsuccessful packet delivery at

the receiver is acknowledged to the sender within the same sampling time period. The set \mathcal{G} corresponds to the information available at the controller under communication protocols in which the sender receives no feedback about the delivery of the transmitted packet to the receiver (UDP-like). The UDP-like schemes are simpler to implement than the TCP-like schemes from a communication standpoint. Moreover UDP-like protocols includes broadcasting which is not feasible under TCP-like protocols. However, UDP-like protocols provide a leaner information set. The goal of this paper is to design optimal LQG controllers and to estimate their closed-loop performance for both TCP-like and UDP-like protocols.

IV. OPTIMAL ESTIMATION

We start defining the following variables:

$$\begin{aligned} \hat{x}_{k|k} &\triangleq \mathbb{E}[x_k | \mathcal{I}_k] \\ e_{k|k} &\triangleq x_k - \hat{x}_{k|k} \\ P_{k|k} &\triangleq \mathbb{E}[e_{k|k} e'_{k|k} | \mathcal{I}_k]. \end{aligned} \quad (7)$$

Derivations below will make use of the following facts:

Lemma 4.1: The following facts are true [39]:

- (a) $\mathbb{E}[(x_k - \hat{x}_k) \hat{x}'_k | \mathcal{I}_k] = \mathbb{E}[e_{k|k} \hat{x}'_k | \mathcal{I}_k] = 0$;
- (b) $\mathbb{E}[x'_k S x_k | \mathcal{I}_k] = \hat{x}'_k S \hat{x}_k + \text{trace}(S P_{k|k})$, $\forall S \geq 0$;
- (c) $\mathbb{E}[\mathbb{E}[g(x_{k+1}) | \mathcal{I}_{k+1}] | \mathcal{I}_k] = \mathbb{E}[g(x_{k+1}) | \mathcal{I}_k]$, $\forall g(\cdot)$.

We now make the following computations which we use to derive the optimal LQG controller

$$\begin{aligned} \mathbb{E}[x'_{k+1} S x_{k+1} | \mathcal{I}_k] &= \mathbb{E}[x'_k A' S A x_k | \mathcal{I}_k] \\ &+ \bar{\nu} u'_k B' S B u_k + 2\bar{\nu} u'_k B' S A \hat{x}_{k|k} + \text{trace}(S Q) \end{aligned} \quad (8)$$

where both the independence of ν_k , w_k , x_k , and the zero-mean property of w_k are exploited. The previous expectation holds true for both the information sets, i.e., $\mathcal{I}_k = \mathcal{F}_k$ or $\mathcal{I}_k = \mathcal{G}_k$. Also

$$\begin{aligned} \mathbb{E}[e'_{k|k} T e_{k|k} | \mathcal{I}_k] &= \text{trace} \left(T \mathbb{E}[e_{k|k} e'_{k|k} | \mathcal{I}_k] \right) \\ &= \text{trace}(T P_{k|k}), \quad \forall T \geq 0. \end{aligned}$$

The equations for the optimal estimator are different whether TCP-like or UDP-like communication protocols are used.

A. Estimator Design Under TCP-Like Protocols

Equations for optimal estimator are derived using arguments similar to those used in standard Kalman filtering. The innovation step is given by

$$\hat{x}_{k+1|k} \triangleq A\mathbb{E}[x_k|\mathcal{F}_k] + \nu_k B u_k = A\hat{x}_{k|k} + \nu_k B u_k \quad (9)$$

$$e_{k+1|k} \triangleq x_{k+1} - \hat{x}_{k+1|k} = A e_{k|k} + w_k \quad (10)$$

$$P_{k+1|k} \triangleq \mathbb{E}\left[e_{k+1|k} e'_{k+1|k} | \nu_k, \mathcal{F}_k\right] = A P_{k|k} A' + Q \quad (11)$$

where the independence of w_k and \mathcal{F}_k , and the requirement that u_k is a deterministic function of \mathcal{F}_k , are used. Since y_{k+1} , γ_{k+1} , w_k and \mathcal{F}_k are independent, the correction step is given by

$$\hat{x}_{k+1|k+1} = \hat{x}_{k+1|k} + \gamma_{k+1} K_{k+1} (y_{k+1} - C \hat{x}_{k+1|k}) \quad (12)$$

$$\begin{aligned} e_{k+1|k+1} &\triangleq x_{k+1} - \hat{x}_{k+1|k+1} \\ &= (I - \gamma_{k+1} K_{k+1} C) e_{k+1|k} - \gamma_{k+1} K_{k+1} v_{k+1} \end{aligned} \quad (13)$$

$$P_{k+1|k+1} = P_{k+1|k} - \gamma_{k+1} K_{k+1} C P_{k+1|k} \quad (14)$$

$$K_{k+1} \triangleq P_{k+1|k} C' (C P_{k+1|k} C' + R)^{-1} \quad (15)$$

where we simply applied the standard derivation for the time varying Kalman filter using the following time varying system matrices: $A_k = A$, $C_k = \gamma_k C$, and $\text{Cov}(v_k) = R$.

B. Estimator Design Under UDP-Like Protocols

We derive the equations for the optimal estimator using similar arguments as in the standard Kalman filtering equations. The innovation step is given by

$$\begin{aligned} \hat{x}_{k+1|k} &\triangleq \mathbb{E}[x_{k+1} | \mathcal{G}_k] = \mathbb{E}[A x_k + \nu_k B u_k + w_k | \mathcal{G}_k] \\ &= A \hat{x}_{k|k} + \bar{\nu} B u_k \end{aligned} \quad (16)$$

$$\begin{aligned} e_{k+1|k} &\triangleq x_{k+1} - \hat{x}_{k+1|k} \\ &= A e_{k|k} + (\nu_k - \bar{\nu}) B u_k + w_k \end{aligned} \quad (17)$$

$$\begin{aligned} P_{k+1|k} &\triangleq \mathbb{E}\left[e_{k+1|k} e'_{k+1|k} | \mathcal{G}_k\right] \\ &= A P_{k|k} A' + \bar{\nu} (1 - \bar{\nu}) B u_k u_k' B' + Q \end{aligned} \quad (18)$$

where we used the independence and zero-mean of w_k , $(\nu_k - \bar{\nu})$, and \mathcal{G}_k , and the fact that u_k is a deterministic function of the information set \mathcal{G}_k . Note how under UDP-like communication, differently from TCP-like, the error covariance $P_{k+1|k}$ depends explicitly on the control input u_k . This is the main difference with control feedback systems under TCP-like protocols.

The correction step is the same as for the TCP case

$$\begin{aligned} \hat{x}_{k+1|k+1} &= \hat{x}_{k+1|k} + \gamma_{k+1} K_{k+1} (y_{k+1} - C \hat{x}_{k+1|k}) \\ P_{k+1|k+1} &= P_{k+1|k} - \gamma_{k+1} K_{k+1} C P_{k+1|k}, \end{aligned} \quad (19)$$

$$K_{k+1} \triangleq P_{k+1|k} C' (C P_{k+1|k} C' + R)^{-1} \quad (20)$$

where again we considered a time varying system with $A_k = A$ and $C_k = \gamma_k C$ as we did for the optimal estimator under TCP-like protocols.

V. OPTIMAL CONTROL UNDER TCP-LIKE PROTOCOLS

Derivation of the optimal feedback control law and the corresponding value for the objective function will follow the dynamic programming approach based on the cost-to-go iterative procedure.

Define the optimal value function $V_k(x_k)$ as follows:

$$\begin{aligned} V_N(x_N) &\triangleq \mathbb{E}[x_N' W_N x_N | \mathcal{F}_N] \\ V_k(x_k) &\triangleq \min_{u_k} \mathbb{E}[x_k' W_k x_k + \nu_k u_k' U_k u_k \\ &\quad + V_{k+1}(x_{k+1}) | \mathcal{F}_k] \end{aligned} \quad (21)$$

where $k = N - 1, \dots, 1$. Using dynamic programming theory [40], one can show that $J_N^* = V_0(x_0)$. Under TCP-like protocols the following lemma holds true:

Lemma 5.1: The value function $V_k(x_k)$ defined in (21) for the system dynamics of (1)–(3) under TCP-like protocols can be written as

$$V_k(x_k) = \mathbb{E}[x_k' S_k x_k | \mathcal{F}_k] + c_k, \quad k = N, \dots, 0 \quad (22)$$

where the matrix S_k and the scalar c_k can be computed recursively as follows:

$$\begin{aligned} S_k &= A' S_{k+1} A + W_k \\ &\quad - \bar{\nu} A' S_{k+1} B (B' S_{k+1} B + U_k)^{-1} B' S_{k+1} A \end{aligned} \quad (23)$$

$$\begin{aligned} c_k &= \text{trace}((A' S_{k+1} A + W_k - S_k) P_{k|k}) \\ &\quad + \text{trace}(S_{k+1} Q) + \mathbb{E}[c_{k+1} | \mathcal{F}_k] \end{aligned} \quad (24)$$

with initial values $S_N = W_N$ and $c_N = 0$. Moreover the optimal control input is given by

$$u_k = -(B' S_{k+1} B + U_k)^{-1} B' S_{k+1} A \hat{x}_{k|k} = L_k \hat{x}_{k|k}. \quad (25)$$

Proof: The proof employs an induction argument. The claim is clearly true for $k = N$ with the choice of parameters

$S_N = W_N$ and $c_N = 0$. Suppose now that the claim is true for $k + 1$, i.e., $V_{k+1}(x_{k+1}) = \mathbb{E}[x'_{k+1}S_{k+1}x_{k+1} | \mathcal{F}_{k+1}] + c_{k+1}$. The value function at time step k is the following:

$$\begin{aligned}
 V_k(x_k) &= \min_{u_k} \mathbb{E}[x'_k W_k x_k + \nu_k u'_k U_k u_k + V_{k+1}(x_{k+1}) | \mathcal{F}_k] \\
 &= \min_{u_k} \mathbb{E}[x'_k W_k x_k + \nu_k u'_k U_k u_k + \mathbb{E}[c_{k+1} | \mathcal{F}_k]] \\
 &= \min_{u_k} \mathbb{E}[x'_k W_k x_k + \nu_k u'_k U_k u_k \\
 &\quad + x'_{k+1} S_{k+1} x_{k+1} + c_{k+1} | \mathcal{F}_k] \\
 &= \mathbb{E}[x'_k W_k x_k + x'_k A' S_{k+1} A x_k | \mathcal{F}_k] \\
 &\quad + \text{trace}(S_{k+1} Q) + \mathbb{E}[c_{k+1} | \mathcal{F}_k] \\
 &\quad + \bar{\nu} \min_{u_k} (u'_k (U_k + B' S_{k+1} B) u_k \\
 &\quad + 2u'_k B' S_{k+1} A \hat{x}_{k|k}) \quad (26)
 \end{aligned}$$

where we used Lemma 1(c) to get the third equality, and (8) to obtain the last equality. The value function is a quadratic function of the input, therefore, the minimizer can be simply obtained by solving $\partial V_k / \partial u_k = 0$, which gives (25). The optimal feedback is, thus, a simple linear function of the estimated state. If we substitute the minimizer back into (26) we get

$$\begin{aligned}
 V_k(x_k) &= \mathbb{E}[x'_k W_k x_k + x'_k A' S_{k+1} A x_k | \mathcal{I}_k] \\
 &\quad + \text{trace}(S_{k+1} Q) + \mathbb{E}[c_{k+1} | \mathcal{I}_k] \\
 &\quad - \bar{\nu} \hat{x}'_{k|k} A' S_{k+1} B (U_k + B' S_{k+1} B)^{-1} B' S_{k+1} A \hat{x}_{k|k} \\
 &= \mathbb{E}[x'_k W_k x_k + x'_k A' S_{k+1} A x_k - \bar{\nu} x'_k A' S_{k+1} B \\
 &\quad \times (U_k + B' S_{k+1} B)^{-1} B' S_{k+1} A x_k | \mathcal{I}_k] \\
 &\quad + \text{trace}(S_{k+1} Q) + \mathbb{E}[c_{k+1} | \mathcal{I}_k] \\
 &\quad + \bar{\nu} \text{trace}(A' S_{k+1} B (U_k + B' S_{k+1} B)^{-1} B' S_{k+1} P_{k|k})
 \end{aligned}$$

where we used Lemma 1(b). Therefore, the claim given by (22) is satisfied also for time step k for all x_k if and only if the (23) and (24) are satisfied. ■

Since $J_N^*(\bar{x}_0, P_0) = V_0(x_0)$, from the lemma it follows that the cost function for the optimal LQG using TCP-like protocols is given by

$$\begin{aligned}
 J_N^* &= \bar{x}'_0 S_0 \bar{x}_0 + \text{trace}(S_0 P_0) + \sum_{k=0}^{N-1} \text{trace}(S_{k+1} Q) \\
 &\quad + \sum_{k=0}^{N-1} \text{trace}((A' S_{k+1} A + W_k - S_k) \mathbb{E}_\gamma[P_{k|k}]) \quad (27)
 \end{aligned}$$

where we used the fact $\mathbb{E}[x'_0 S_0 x_0] = \bar{x}'_0 S_0 \bar{x}_0 + \text{trace}(S_0 P_0)$, and $\mathbb{E}_\gamma[\cdot]$ explicitly indicates that the expectation is calculated with respect to the arrival sequence $\{\gamma_k\}$.

It is important to remark that the error covariance matrices $\{P_{k|k}\}_{k=0}^N$ are stochastic since they depend on the sequence $\{\gamma_k\}$. Moreover, since the matrix $P_{k+1|k+1}$ is a nonlinear function of the previous time step matrix covariance $P_{k|k}$, as can be observed from (11) and (15), the exact expected value of these matrices, $\mathbb{E}_\gamma[P_{k|k}]$, cannot be computed analytically, as shown in [37]. However, they can be bounded by computable deterministic quantities, as shown in [37] from which we can derive the following lemma:

Lemma 5.2 ([37]): The expected error covariance matrix $\mathbb{E}_\gamma[P_{k|k}]$ satisfies the following bounds:

$$\tilde{P}_{k|k} \leq \mathbb{E}_\gamma[P_{k|k}] \leq \hat{P}_{k|k} \quad \forall k \geq 0 \quad (28)$$

where the matrices $\hat{P}_{k|k}$ and $\tilde{P}_{k|k}$ can be computed as follows:

$$\begin{aligned}
 \hat{P}_{k+1|k} &= A \hat{P}_{k|k-1} A' + Q - \bar{\gamma} A \hat{P}_{k|k-1} C' \\
 &\quad \times (C \hat{P}_{k|k-1} C' + R)^{-1} C \hat{P}_{k|k-1} A' \quad (29)
 \end{aligned}$$

$$\begin{aligned}
 \hat{P}_{k|k} &= \hat{P}_{k|k-1} - \bar{\gamma} \hat{P}_{k|k-1} C' \\
 &\quad \times (C \hat{P}_{k|k-1} C' + R)^{-1} C \hat{P}_{k|k-1} \quad (30)
 \end{aligned}$$

$$\tilde{P}_{k+1|k} = (1 - \bar{\gamma}) A \tilde{P}_{k|k-1} A' + Q \quad (31)$$

$$\tilde{P}_{k|k} = (1 - \bar{\gamma}) \tilde{P}_{k|k-1} \quad (32)$$

where the initial conditions are $\hat{P}_{0|0} = \tilde{P}_{0|0} = P_0$.

Proof: The argument is based on the observation that the matrices $P_{k+1|k}$ and $P_{k|k}$ are concave and monotonic functions of $P_{k|k-1}$. The proof is offered in [37] and is thus omitted. ■

From this lemma it follows that also the minimum achievable cost J_N^* , given by (27), cannot be computed analytically, but can be bounded as follows:

$$J_N^{\min} \leq J_N^* \leq J_N^{\max} \quad (33)$$

$$\begin{aligned}
 J_N^{\max} &= \bar{x}'_0 S_0 \bar{x}_0 + \text{trace}(S_0 P_0) + \sum_{k=0}^{N-1} \text{trace}(S_{k+1} Q) \\
 &\quad + \sum_{k=0}^{N-1} \text{trace}((A' S_{k+1} A + W_k - S_k) \hat{P}_{k|k}) \quad (34)
 \end{aligned}$$

$$\begin{aligned}
 J_N^{\min} &= \bar{x}'_0 S_0 \bar{x}_0 + \text{trace}(S_0 P_0) + \sum_{k=0}^{N-1} \text{trace}(S_{k+1} Q) \\
 &\quad + \sum_{k=0}^{N-1} \text{trace}((A' S_{k+1} A + W_k - S_k) \tilde{P}_{k|k}). \quad (35)
 \end{aligned}$$

The results derived above can be summarized as follows:

Theorem 5.3: Consider the system (1)–(3) and consider the problem of minimizing the cost function (5) within the class of admissible policies $u_k = f(\mathcal{F}_k)$, where \mathcal{F}_k is the information available under TCP-like schemes, given in (4). Then, the following hold.

- a) The separation principle still holds for TCP-like communication, since the optimal estimator, given by (9), (11), (12), (14), and (15), is independent of the control input u_k .
- b) The optimal estimator gain K_k is time-varying and stochastic since it depends on the past observation arrival sequence $\{\gamma_j\}_{j=1}^k$.
- c) The optimal control input, given by (25) and (23) with initial condition $S_N = W_N$, is a linear function of the estimated state $\hat{x}_{k|k}$, i.e., $u_k = L_k \hat{x}_{k|k}$, and the optimal gain L_k is independent of the process sequences $\{\nu_k, \gamma_k\}$.

The infinite horizon LQG can be obtained by taking the limit for $N \rightarrow +\infty$ of the previous equations. However, as explained above, the matrices $\{P_{k|k}\}$ depend nonlinearly on the specific realization of the observation sequence $\{\gamma_k\}$, therefore, the expected error covariance matrices $\mathbb{E}_\gamma[P_{k|k}]$ and the minimal cost J_N^* cannot be computed analytically and do not seem to have limit [37]. Differently from standard LQG optimal regulator [41], the estimator gain does not converge to a steady state value, but is strongly time-varying due to its dependence on the arrival process $\{\gamma_k\}$. Moreover, while the standard LQG optimal regulator always stabilizes the original system, in the case of observation and control packet losses, the stability can be lost if the arrival probabilities $\bar{\nu}$, $\bar{\gamma}$ are below a certain threshold. This observation comes from the study of existence of solution for a Modified Riccati Algebraic Equation (MARE), $S = \Pi(S, A, B, W, U, \nu)$, which was introduced by [42] and studied in [25], [37] and [43], where the nonlinear operator $\Pi(\cdot)$ is defined as follows:

$$\Pi(S, A, B, Q, R, \nu) \triangleq A'SA + W - \nu A'SB(B'SB + U)^{-1}B'SA. \quad (36)$$

In particular, (23), i.e., $S_{k+1} = \Pi(S_k, A, B, W, U, \nu)$, is the dual of the estimator equation presented in [37], i.e., $P_{k+1} = \Pi(P_k, A', C', Q, R, \gamma)$. The results about the MARE are summarized in the following lemma

Lemma 5.4: Consider the modified Riccati equation defined in (36). Let A be unstable, (A, B) be controllable, and $(A, W^{1/2})$ be observable. Then, the following hold.

- a) The MARE has a unique strictly positive definite solution S_∞ if and only if $\nu > \nu_c$, where ν_c is the critical arrival probability defined as

$$\nu_c \triangleq \inf_{\nu} \{0 \leq \nu \leq 1 \mid S = \Pi(S, A, B, W, U, \nu), S \geq 0\}.$$

- b) The critical probability ν_c satisfy the following analytical bounds:

$$\begin{aligned} p_{\min} &\leq \nu_c \leq p_{\max} \\ p_{\min} &\triangleq 1 - \frac{1}{\max_i |\lambda_i^u(A)|^2} \\ p_{\max} &\triangleq 1 - \frac{1}{\prod_i |\lambda_i^u(A)|^2} \end{aligned}$$

where $\lambda_i^u(A)$ are the unstable eigenvalues of A . Moreover, $\nu_c = p_{\min}$ when B is square and invertible, and $\nu_c = p_{\max}$ when B is rank one.

- c) The critical probability can be numerically computed via the solution of the following quasi-convex LMIs optimization problem

$$\nu_c = \operatorname{argmin}_{\bar{\nu}} \Psi_{\bar{\nu}}(Y, Z) > 0, \quad 0 \leq Y \leq I.$$

$$\Psi_{\bar{\nu}}(Y, Z) =$$

$$\begin{bmatrix} Y & Y & \sqrt{\bar{\nu}}ZU^{\frac{1}{2}} & \sqrt{\bar{\nu}}(YA' + ZB') & \sqrt{1 - \bar{\nu}}YA' \\ Y & W^{-1} & 0 & 0 & 0 \\ \sqrt{\bar{\nu}}U^{\frac{1}{2}}Z' & 0 & I & 0 & 0 \\ \sqrt{\bar{\nu}}(AY + BZ') & 0 & 0 & Y & 0 \\ \sqrt{1 - \bar{\nu}}AY & 0 & 0 & 0 & Y \end{bmatrix}.$$

- d) If $\nu > \nu_c$, then $\lim_{k \rightarrow +\infty} S_k = S_\infty$ for all initial conditions $S_0 \geq 0$, where $S_{k+1} = \Pi(S_k, A, B, W, U, \nu)$.

The proof of facts a), c), and d) can be found in [37]. The proof $\nu_c = p_{\min}$ when B is square and invertible can be found in [42], and the proof $\nu_c = p_{\max}$ when B is rank one in [25].

Differently from standard LQG optimal regulator, the estimator gain does not converge to a steady state value.

In [37], statistical analysis of the optimal estimator was given, which we report here for convenience:

Theorem 5.5 ([37]): Consider the system (1)–(3) and the optimal estimator under TCP-like protocols, given by (9), (11), (12), (14), and (15). Assume that $(A, Q^{1/2})$ is controllable, (A, C) is observable, and A is unstable. Then there exists a critical observation arrival probability γ_c , such that the expectation of estimator error covariance is bounded if and only if the observation arrival probability is greater than the critical arrival probability, i.e.,

$$\mathbb{E}_\gamma[P_{k|k}] \leq M \forall k \text{ iff } \bar{\gamma} > \gamma_c$$

where M is a positive definite matrix possibly dependent on P_0 . Moreover, it is possible to compute a lower and an upper bound for the critical observation arrival probability γ_c , i.e., $p_{\min} \leq \gamma_c \leq \gamma_{\max} \leq p_{\max}$, where

$$\gamma_{\max} \triangleq \inf_{\gamma} \{0 \leq \gamma \leq 1, |P = \Pi(P, A', C', Q, R, \gamma), P \geq 0|\}$$

where p_{\min} and p_{\max} are defined in Lemma 5.4.

The proof of the previous theorem can be found in [37].

Using the previous theorem and the results from the previous section, we can prove the following theorem for the infinite horizon optimal LQG under TCP-like protocols:

Theorem 5.6: Consider the same system as defined in the previous theorem with the following additional hypothesis: $W_N = W_k = W$ and $U_k = U$. Moreover, let (A, B) and $(A, Q^{1/2})$ be controllable, and let (A, C) and $(A, W^{1/2})$ be observable. Moreover, suppose that $\bar{\nu} > \nu_c$ and $\bar{\gamma} > \gamma_{\max}$, where ν_c and γ_{\max} are defined in Lemma 5.4 and in Theorem 5.5, respectively. Then we have the following.

- a) The infinite horizon optimal controller gain is constant

$$\lim_{k \rightarrow \infty} L_k = L_\infty = -(B'S_\infty B + U)^{-1} B'S_\infty A. \quad (37)$$

- b) The infinite horizon optimal estimator gain K_k , given by (15), is stochastic and time-varying since it depends on the past observation arrival sequence $\{\gamma_j\}_{j=1}^k$.
- c) The expected minimum cost can be bounded by two deterministic sequences

$$\frac{1}{N} J_N^{\min} \leq \frac{1}{N} J_N^* \leq \frac{1}{N} J_N^{\max} \quad (38)$$

where J_N^{\min}, J_N^{\max} converge to the following values:

$$\begin{aligned} J_\infty^{\max} &\triangleq \lim_{N \rightarrow +\infty} \frac{1}{N} J_N^{\max} \\ &= \text{trace}((A'S_\infty A + W - S_\infty) \\ &\quad \times (\widehat{P}_\infty - \bar{\gamma} \widehat{P}_\infty C' (C\widehat{P}_\infty C' + R)^{-1} C\widehat{P}_\infty)) \\ &\quad + \text{trace}(S_\infty Q) \\ J_\infty^{\min} &\triangleq \lim_{N \rightarrow +\infty} \frac{1}{N} J_N^{\min} \\ &= (1 - \bar{\gamma}) \text{trace}((A'S_\infty A + W - S_\infty) \widetilde{P}_\infty) \\ &\quad + \text{trace}(S_\infty Q) \end{aligned}$$

and the matrices $S_\infty, \bar{P}_\infty, \underline{P}_\infty$ are the positive definite solutions of the following equations:

$$\begin{aligned} S_\infty &= A'S_\infty A + W - \bar{\nu} A'S_\infty B (B'S_\infty B + U)^{-1} B'S_\infty A \\ \bar{P}_\infty &= A\bar{P}_\infty A' + Q - \bar{\gamma} A\bar{P}_\infty C' (C\bar{P}_\infty C' + R)^{-1} C\bar{P}_\infty A' \\ \underline{P}_\infty &= (1 - \bar{\gamma}) A\underline{P}_\infty A' + Q \end{aligned}$$

Proof:

- a) Since by hypothesis $\bar{\nu} > \nu_c$, from Lemma 5.4(d) follows that $\lim_{k \rightarrow +\infty} S_k = S_\infty$. Therefore, (37) follows from (25).
- b) This follows from the dependence on the arrival sequence $\{\gamma_k\}$ of the optimal state estimator given by (9), (11), (12), (14), and (15).
- c) Equation (29) can be written in terms of the MARE as $\widehat{P}_{k+1|k} = \Pi(\widehat{P}_{k|k-1}, A', C', Q, R, \gamma)$, therefore, since $\bar{\gamma} > \gamma_{\max}$ from Lemma 5.4(d) it follows that $\lim_{k \rightarrow +\infty} \widehat{P}_{k|k-1} = \bar{P}_\infty$, where \bar{P}_∞ is the solution of the MARE $\bar{P}_\infty = \Pi(\bar{P}_\infty, A', C', Q, R, \gamma)$. Also $\lim_{k \rightarrow +\infty} \widehat{P}_{k|k-1} = \underline{P}_\infty$, where $\underline{P}_{k|k-1}$ is defined in (31) and \underline{P}_∞ is the solution of the Lyapunov equation $\underline{P}_\infty = \bar{A}\underline{P}_\infty \bar{A}' + Q$, where $\bar{A} = \sqrt{1 - \bar{\gamma}} A$. Such solution clearly exists since $\sqrt{1 - \bar{\gamma}} < (1/p_{\min}) = 1/\max_i |\lambda_i^u(A)|$ and thus the matrix \bar{A} is strictly stable. From (30) and (32) it follows that $\lim_{k \rightarrow +\infty} \widehat{P}_{k|k} = \bar{P}_\infty - \bar{\gamma} \bar{P}_\infty C' (C\bar{P}_\infty C' + R)^{-1} C\bar{P}_\infty$ and $\lim_{k \rightarrow +\infty} \widehat{P}_{k|k} = (1 - \bar{\gamma}) \underline{P}_\infty$. Also $\lim_{k \rightarrow +\infty} S_{k+1} = \lim_{k \rightarrow +\infty} S_k = S_\infty$. Finally from (33)–(35) and the previous observations follow the claim. ■

VI. OPTIMAL CONTROL UNDER UDP-LIKE PROTOCOLS

In this section, we show that the optimal LQG controller, under UDP-like communication protocols, is in general *not* a linear function of the state estimate. Consequently,

The separation principle does not hold since the estimator error covariance depends on the control input.

estimation and controller design cannot be treated independently. For this, we construct a counter-example considering a simple scalar system and we proceed using the dynamic programming approach. Consider the scalar system where $A = 1$, $B = 1$, $C = 1$, $W_N = W_k = 1$, $U_k = 0$, $R = 1$, $Q = 0$. Analogously to the TCP case, we define the value function, $V_k(x_k)$, as in (21) where we just need to substitute the information set \mathcal{F}_k with \mathcal{G}_k . For $k = N$, the value function is given by $V_N(x_N) = \mathbb{E}[x'_N W_N x_N | \mathcal{G}_N] = \mathbb{E}[x_N^2 | \mathcal{G}_N]$. For $k = N - 1$ we have

$$\begin{aligned} V_{N-1}(x_{N-1}) &= \min_{u_{N-1}} \mathbb{E}[x_{N-1}^2 + V_N(x_N) | \mathcal{G}_{N-1}] \\ &= \min_{u_{N-1}} (\mathbb{E}[2x_{N-1}^2 | \mathcal{G}_{N-1}] + \bar{\nu} u_{N-1}^* \\ &\quad + 2\bar{\nu} u_{N-1} \hat{x}_{N-1|N-1}) \end{aligned}$$

where we used the independence of ν_{N-1} and \mathcal{G}_{N-1} , and the fact that u_{N-1} is a deterministic function of the information set \mathcal{G}_{N-1} . The cost is a quadratic function of the input u_{N-1} , therefore, the minimizer can be simply obtained by finding $\partial V_{N-1} / \partial u_{N-1} = 0$, which is given by $u_{N-1}^* = -\hat{x}_{N-1|N-1}$. If we substitute back u_{N-1}^* into the value function we have

$$\begin{aligned} V_{N-1}(x_{N-1}) &= \mathbb{E}[2x_{N-1}^2 | \mathcal{G}_{N-1}] - \bar{\nu} \hat{x}_{N-1|N-1}^2 \\ &= \mathbb{E}[(2 - \bar{\nu})x_{N-1}^2 | \mathcal{G}_{N-1}] + \bar{\nu} P_{N-1|N-1} \end{aligned}$$

where we used Lemma 4.1(b).

Using the previous equations we proceed to compute the value function for $k = N - 2$

$$\begin{aligned} V_{N-2}(x_{N-2}) &= \min_{u_{N-2}} \mathbb{E}[x_{N-2}^2 + V_{N-1}(x_{N-1}) | \mathcal{G}_{N-2}] \\ &= \mathbb{E}[(3 - \bar{\nu})x_{N-2}^2 | \mathcal{G}_{N-2}] + \bar{\gamma} + \bar{\nu} P_{N-2|N-2} \\ &\quad + \bar{\nu}(1 - \bar{\gamma})P_{N-2|N-2} \\ &\quad + \min_{u_{N-2}} \left((\bar{\nu}(2 - \bar{\nu})u_{N-2}^2 + 2\bar{\nu}(2 - \bar{\nu})u_{N-2} \hat{x}_{N-2|N-2} \cdot \right. \\ &\quad \left. + \bar{\nu}^2(1 - \bar{\nu})(1 - \bar{\gamma})u_{N-2}^2 + \bar{\nu}\bar{\gamma} \right. \\ &\quad \left. \times \frac{1}{P_{N-2|N-2} + \bar{\nu}(1 - \bar{\nu})u_{N-2}^2 + 1} \right). \quad (39) \end{aligned}$$

The first three terms within parenthesis are convex quadratic functions of the control input u_{N-2} , however the last term is not. Therefore, the minimizer u_{N-2}^* is, in general, a nonlinear function of the information set \mathcal{G}_k . The nonlinearity of the optimal controller arises from the fact that the correction error covariance matrix $P_{k+1|k+1}$ is a nonlinear function of the innovation error covariance $P_{k+1|k}$, as it can be seen in (19) and (20). The only case when $P_{k+1|k+1}$ is linear in $P_{k+1|k}$ is when measurement noise covariance $R = 0$ and the observation matrix C is square and invertible, from which follows that the optimal control is linear in the estimated states.

We can summarize these results in the following theorem:

Theorem 6.1: Let us consider the stochastic system defined in (1) with horizon $N \geq 2$. Then the following hold.

- a) The separation principle does not hold since the estimator error covariance depends on the control input, as shown in (18).
- b) The optimal control feedback $u_k = g_k^*(\mathcal{G}_k)$ that minimizes the cost functional defined in (5) under UDP-like protocols is, in general, a nonlinear function of information set \mathcal{G}_k .
- c) The optimal control feedback $u_k = g_k^*(\mathcal{G}_k)$ is a linear function of the estimated state $\hat{x}_{k|k}$, i.e., $u_k = L_k^* \hat{x}_{k|k}$, if and only if the matrix C is invertible and there is no measurement noise [36]. In the infinite horizon scenario, the optimal state-feedback gain is constant, i.e., $L_k^* = L_\infty^*$, and can be computed as the solution of a convex optimization problem. A necessary condition for stability of the closed loop system is:

$$|A|^2(\bar{\gamma} + \bar{\nu} - 2\bar{\gamma}\bar{\nu}) < \bar{\gamma} + \bar{\nu} - 2\bar{\gamma}\bar{\nu} \quad (40)$$

where $|A| = \max_i |\lambda_i(A)|$ is the largest eigenvalue of the matrix A . This condition is also sufficient if B is square and invertible.

Proof: (a) This statement is clearly true by inspecting (18), since according to the definition of separation principle the estimate error must not depend on the control input. (b) This claim follows by the counterexample above. (c) As the proof of this claim is long and rather technical we moved it to the Appendix for the interested reader. ■

A graphical representation of the stability bounds are shown in Fig. 2, where we considered a scalar system with parameters $|A| = 1.1$. For the same system we have $p_{\min} = p_{\max} = 1 - 1/|A|^2 = 0.173$, therefore, the critical

probability for the TCP-like protocols is $\gamma_c = \nu_c = p_{\min}$ as stated in Theorem 5.5. The stability bound for UDP-like protocols of (40) is stronger than a similar bound recently reported in [36].

The nonlinearity of the input feedback arises from the fact that the correction error covariance matrix $P_{k+1|k+1}$ is a nonlinear function of the innovation error covariance $P_{k+1|k}$. The only case when $P_{k+1|k+1}$ is linear in $P_{k+1|k}$ is when $R = 0$ and $C = I$, from which follows that the optimal control is linear in the estimated states. However, it is important to remark that the separation principle still

does not hold, since the control input affects the estimator error covariance.

VII. NUMERICAL EXAMPLES

In this section, we show some applications of the theoretical tools developed in the previous sections to evaluate the performance of typical control systems for different communication architectures and protocols.

As a first example we consider the pendubot: a control laboratory experiment consisting of two-link planar robot

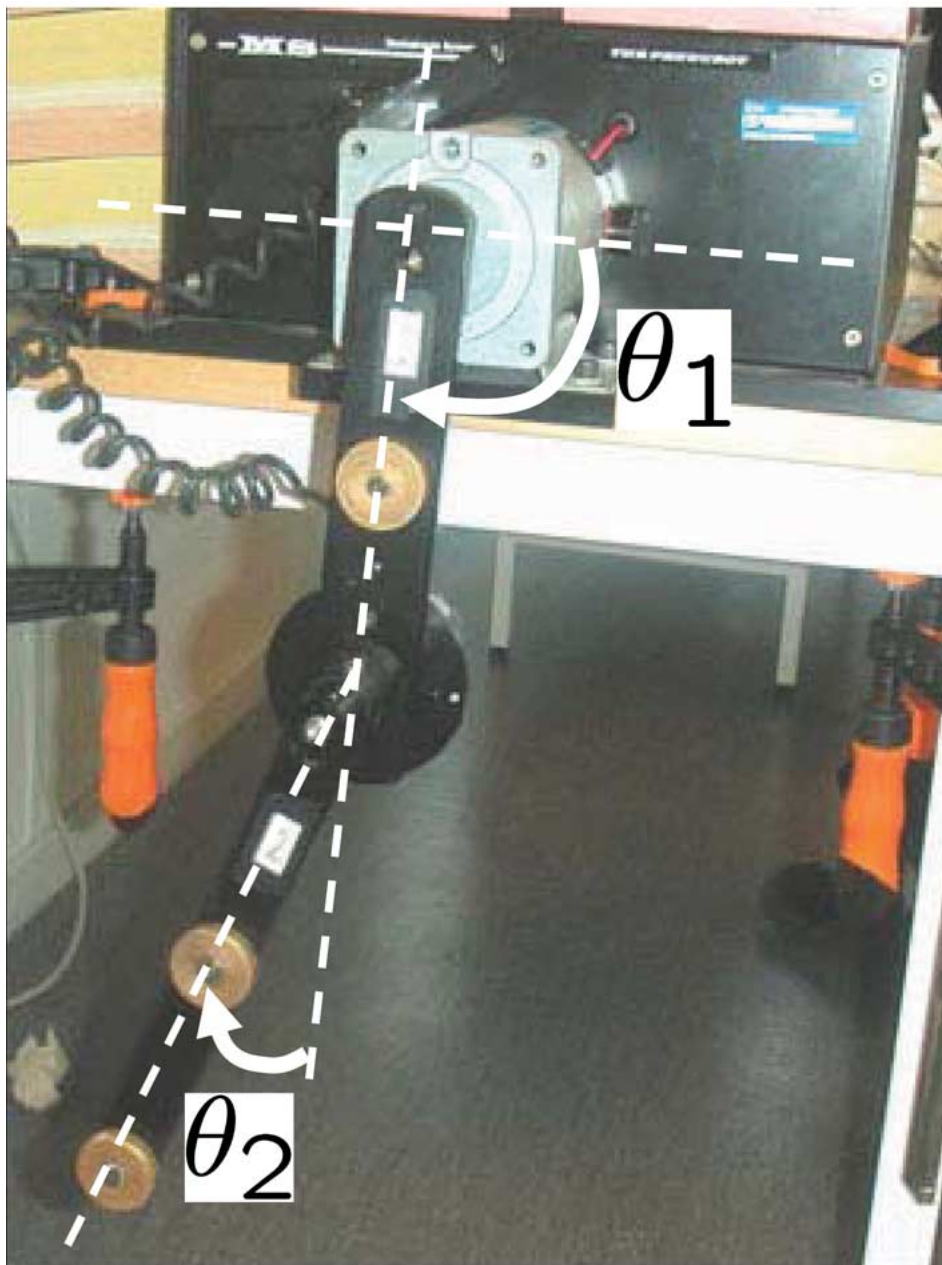

Fig. 3. Photo of Pendubot. Courtesy of Mechatronic Systems, Inc.

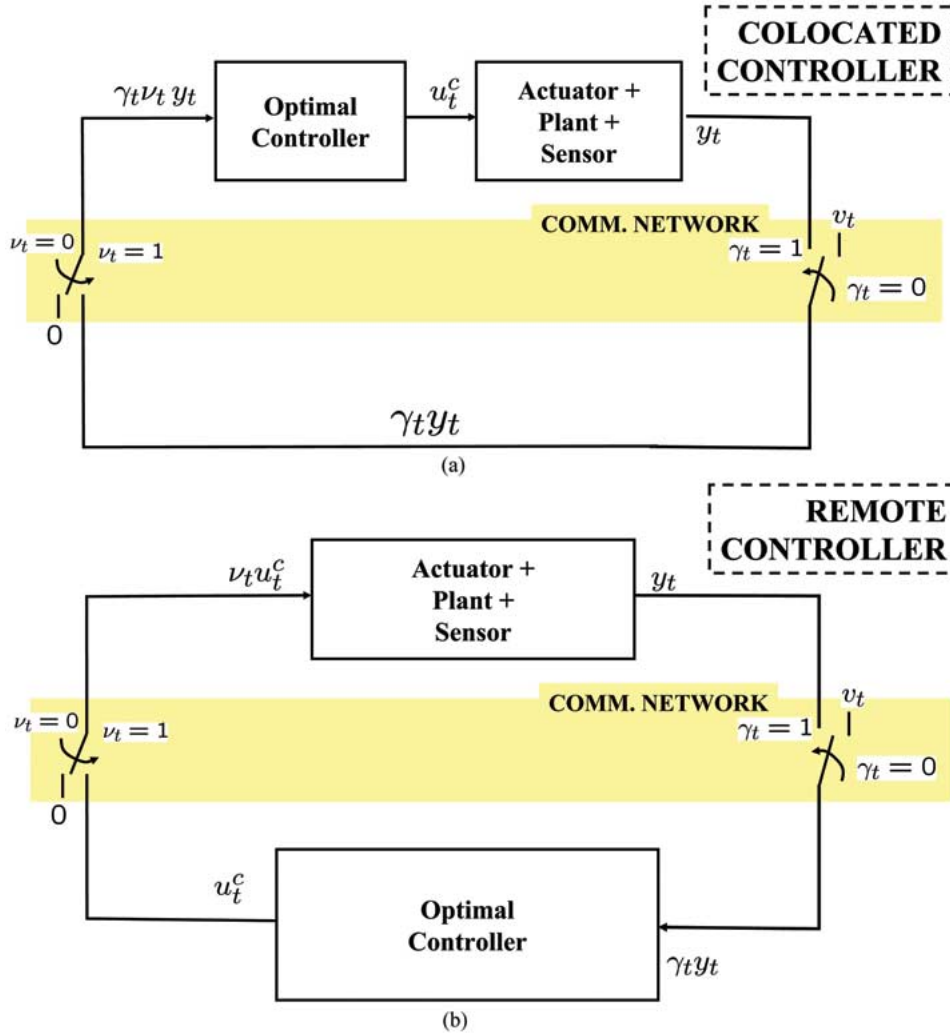

Fig. 4. Different controller placement: colocated with the actuator (top) and remote (bottom).

with torque actuation only on the first link as shown in Fig. 3. We are interested in designing a controller that stabilizes the pendubot in up-right position, corresponding to unstable equilibrium point $\theta_1^* = -\pi/2$, $\theta_2^* = 0$, where the angles θ_1, θ_2 are defined as shown in Fig. 3. We address the interested reader to [44] for more details and references on the pendubot. The state space representation of the system linearized about the the unstable equilibrium point and discretized with sampling period $T_s = 0.005$ [s] is given by

$$A = \begin{bmatrix} 1.001 & 0.005 & 0.000 & 0.000 \\ 0.35 & 1.001 & -0.135 & 0.000 \\ -0.001 & 0.000 & 1.001 & 0.005 \\ -0.375 & -0.001 & 0.590 & 1.001 \end{bmatrix}, B = \begin{bmatrix} 0.001 \\ 0.540 \\ -0.002 \\ -1.066 \end{bmatrix}$$

$$C = \begin{bmatrix} 1 & 0 & 0 & 0 \\ 0 & 0 & 1 & 0 \end{bmatrix}, R = \begin{bmatrix} 0.001 & 0 \\ 0 & 0.001 \end{bmatrix}, U = 2$$

$$Q = qq^T, q = \begin{bmatrix} 0.003 \\ 1.000 \\ -0.005 \\ -2.150 \end{bmatrix}, W = \begin{bmatrix} 5 & 0 & 0 & 0 \\ 0 & 1 & 0 & 0 \\ 0 & 0 & 1 & 0 \\ 0 & 0 & 0 & 1 \end{bmatrix}$$

where $x = [\delta\theta_1, \delta\dot{\theta}_1, \delta\theta_2, \delta\dot{\theta}_2]^T$ and $\delta\theta_i(t) = \theta_i(t) - \theta_i^*$. The matrix A has two stable and two unstable eigenvalues $\text{eig}(A) = (1.061, 1.033, 0.968, 0.941)$. It is easy to verify that the pairs (A, B) and (A, Q) are controllable, (A, C) and (A, W) are observable, and $R > 0$, as required by the assumptions of the theorems presented in the previous sections.

We first compare the performance of the closed loop controller for two different control architecture, as shown in Fig. 4. In the first scenario, we consider actuators with no computational resources, therefore, the controller must be implemented remotely and the control input is transmitted to the actuator via a lossy communication link which adopt a TCP-like protocol. We also assume that the communication links between the sensors and the controller and between the controller and the actuator are independent and have the same arrival probability, i.e., $\bar{\nu} = \bar{\gamma}$. In the second scenario, we consider the use of “smart” actuators, i.e., actuators with sufficient computational resources to implement the optimal controller. In the scenario where the controller is colocated with the actuator, it is equivalent to the TCP-like optimal control with observation arrival probability $\bar{\gamma}_{eq} = \bar{\nu}\bar{\gamma} = \bar{\gamma}^2$ (series of two independent lossy links) and control arrival probability $\bar{\nu}_{eq} = 1$ (no communication link). Fig. 5 shows the upper bound for the minimum infinite horizon cost J_{∞}^{\max} defined in Theorem 5.6. The colocated controller clearly outperforms the performance of the remote controller. This is to be expected as the colocated controller can compensate for observation packet with an optimal filter

and there is no control packet loss. The remote controller, on the other hand, can compensate only for the observation packet loss, but not for the control packet loss. Therefore, when practically feasible, it is always more effective to place the controller as close as possible to the actuators.

As a second example we compare the performance under the TCP-like and UDP-like protocols, as shown in Fig. 1. We consider the pendubot above with the additional assumptions of full state observation, i.e., $C = I_{4 \times 4}$, and no sensor noise, i.e., $R = 0_{4 \times 4}$. Again we assume independent lossy links with the same loss probability $\bar{\nu} = \bar{\gamma}$. Fig. 6 shows the upper bound of minimum cost J_{∞}^{\max} under TCP-like protocols calculated as in Theorem 5.6 and the minimum cost J_{∞}^* under UDP-like protocols calculated as described in Theorem 8.5 in the Appendix. The TCP-like communication protocols give better control performance than UDP-like, however this comes at the price of an higher complexity in the protocol design. Once again tradeoffs between performance and complexity appear.

As a final example we consider a different compensation approach at the actuator site when no computational

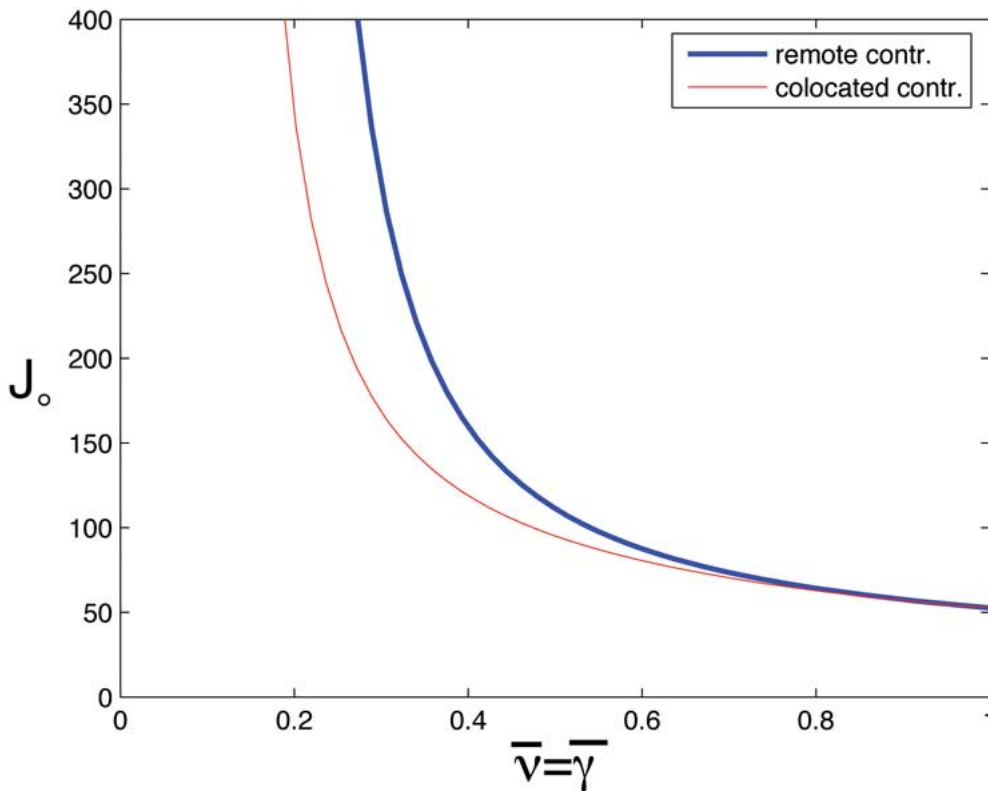

Fig. 5. Upper bounds J_{∞}^{\max} for the minimum cost with respect to two different controller locations under TCP-like protocols: controller colocated with the actuator equivalent to TCP-like performance with $\bar{\gamma}_{eq} = \bar{\gamma}\bar{\nu}$ and $\bar{\nu}_{eq} = 1$ (thin solid line) and controller located remotely from the actuator and connect by a communication network (thick solid line). Cost is calculated for $\bar{\nu} = \bar{\gamma}$.

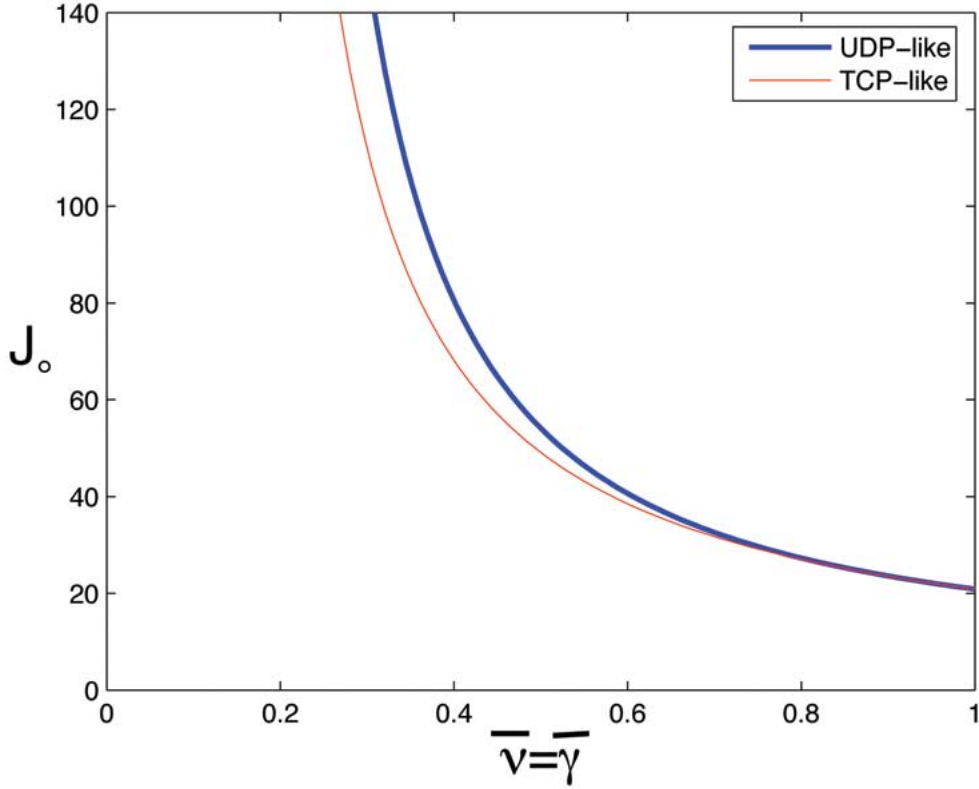

Fig. 6. Minimum cost J_∞ under two different communication protocols: TCP-like (thin solid line) and UDP-like (thick solid line).

resources are available. In this paper, we chose to apply no control when a control packet is lost, $u_k^a = 0$. We call this approach zero-input strategy. Another natural choice is to use the previous control input if the current is lost, i. e., $u_k^a = u_{k-1}^a$ [15]. We call this second approach hold-input strategy. Fig. 7 gives a pictorial representation of these two strategies. We consider a very simple scalar unstable system with parameters $A = 1.2$, $B = C = 1$, $W = U = 1$ and no process and measurement noise, i. e., $R = Q = 0$. We also assume there is only control packet loss with arrival probability $\bar{\nu} = 0.5$ and no observation packet loss, i. e., $\bar{\gamma} = 1$. Since there is no observation loss and there is full state observation with no measurement noise, the optimal control must necessarily be a static feedback and no filter is necessary. The dynamics of the closed loop with zero-input strategy can be written as follows:

$$\begin{aligned} x_{k+1} &= Ax_k + Bu_k^a \\ u_k^a &= \nu_k u_k^c \\ u_k^c &= L_z x_k \end{aligned} \quad (41)$$

and the dynamics for the hold-input strategy as

$$\begin{aligned} x_{k+1} &= Ax_k + Bu_k^a \\ u_k^a &= \nu_k u_k^c + (1 - \nu_k) u_{k-1}^a \\ u_k^c &= L_h x_k. \end{aligned} \quad (42)$$

We compare the performance in terms of the infinite horizon expected total cost $J_\infty = \mathbb{E}[\sum_{k=0}^{\infty} x_k' W x_k + u_k^a' U u_k^a]$. The optimal gain for the zero-input strategy can be computed from (37) and is equal to $L_z^* = -1.02$. However, the exact computation of this expected cost for the hold-input strategy cannot be computed analytically with the tools developed in this paper, therefore, we resort to the computation of the empirical cost for a wide range of control feedback gains L_z and L_z^* . Fig. 8 shows the empirical cost J_∞^{emp} computed as the average cost over 10 000 runs with initial condition $x_0 = 2$, $u_0^a = 0$. Note that the empirical optimal gain and the theoretical optimal gain L_z^* for the zero-strategy are consistent. Surprisingly, the zero-input strategy not only gives a comparable performance with the hold-input strategy but it appears to perform better both

in terms of minimum achievable cost and in term of robustness with respect to feedback gain sensitivity. This is only an example and further rigorous analysis needs to be performed to verify if this is a general result. Nonetheless the zero-input strategy is a fair approach and it is based on the rationale that in a stable closed loop system driven by gaussian noise with zero mean, also the input to the plant is gaussian with zero mean, therefore, using $u_k^a = 0$ when a packet is lost is equivalent of using an unbiased estimate of the input u_k^c generated by the remote controller.

VIII. CONCLUSION AND FUTURE DIRECTIONS

In this paper, we have analyzed the LQG control problem in the case where both observation and control packets may be lost during transmission over a communication channel. This situation arises frequently in distributed systems where sensors, controllers and actuators reside in different physical locations and have to rely on data networks to exchange information. We have presented analysis of the LQG control problem under two classes of protocols: TCP-like and UDP-like. In TCP-like protocols,

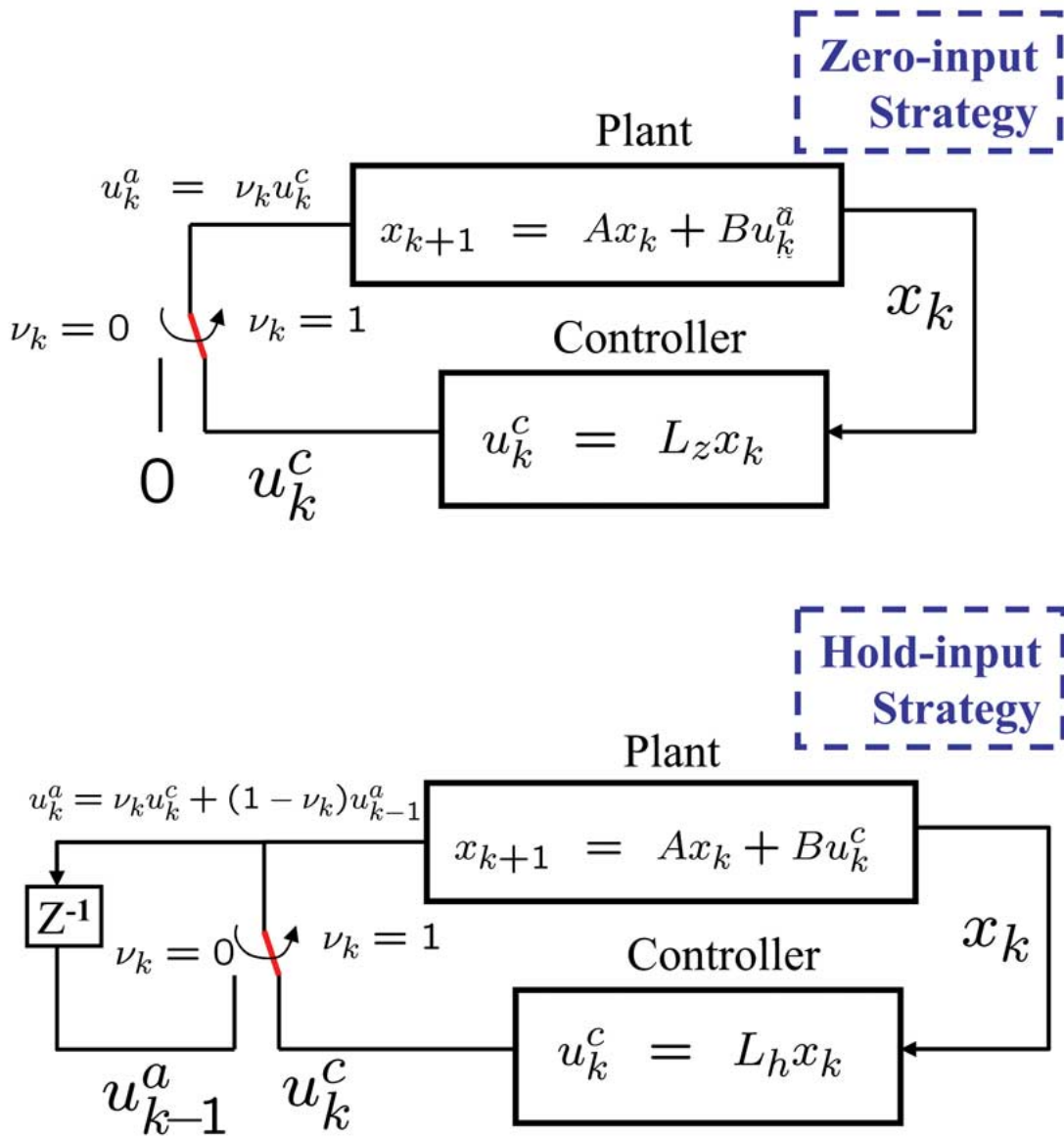

Fig. 7. Compensation approaches for actuators with no computational resources when a control packet is lost: zero-input approach $u_k^a = 0$ (top) and hold-input approach $u_k^a = u_{k-1}^a$ (bottom).

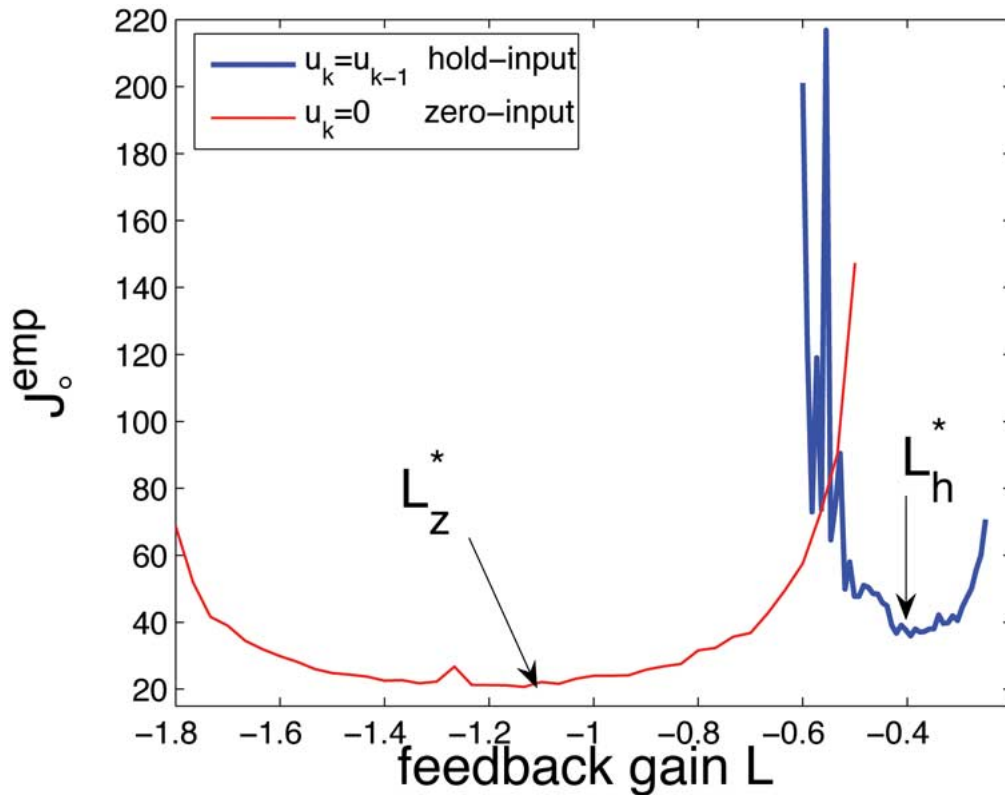

Fig. 8. Empirical cost for different values of the feedback gains L_z and L_h for the zero-input strategy (thin solid line) and hold-input strategy (thick solid line).

acknowledgements of successful transmissions of control packets are provided to the controller, while in UDP-like protocols, no such feedback is provided.

For TCP-like protocols we have solved a general LQG control problem in both the finite and infinite horizon scenarios. We have shown that the optimal control is a linear function of the state and that the separation principle holds. As a consequence, controller design and estimator design are decoupled under TCP-like protocols. However, unlike standard LQG control with no packet loss, the gain of the optimal observer does not converge to a steady state value. Rather, the optimal observer gain is a time-varying stochastic function of the packet arrival process. Several infinite horizon LQG controller design methodologies proposed in the literature impose time-invariance on the controller and are, therefore, suboptimal. In analyzing the infinite horizon problem, we have shown that the infinite horizon cost is bounded if and only if arrival probabilities $\bar{\gamma}$, $\bar{\nu}$ exceed a certain threshold. Thus, the underlying communication channel must be sufficiently reliable in order for LQG optimal controllers to stabilize the plant.

UDP-like protocols present a much more complex problem. We have shown that the lack of acknowledgment of control packets results in the failure of the separation

principle. Estimation and control are now intimately coupled. We have shown that the LQG optimal control is, in general, nonlinear in the estimated state. As a consequence, the optimal control law cannot be determined explicitly in closed form, rendering this solution impractical. In the special case where the state is completely observed (C is invertible and there is no output noise i.e., $R = 0$), the optimal control is indeed linear and can be explicitly computed. We have shown that the set of arrival probabilities $\bar{\gamma}$, $\bar{\nu}$ for which the infinite horizon cost function is bounded, is smaller than the equivalent set for TCP-like protocols. However, for moderate packet loss probabilities the performance of these two classes of protocols is comparable. This makes the simpler UDP-like protocols attractive for networked control systems.

To fully exploit UDP-like protocols it is necessary to have a controller/estimator design methodology for the general case when there is measurement noise and under partial state observation. Although the true LQG optimal controller for UDP-like protocols is time-varying and hard to compute, we might choose to determine the optimal time-invariant LQG controller. Although this is a suboptimal strategy, this controller can be determined explicitly, rendering implementation simple and computationally effective, as recently presented in [45].

We have shown that underlying communication protocols intimately affect the overall performance of networked control systems. For example the separation principle of LQG optimal control, a milestone in classical control theory on which many modern controller design techniques rest, does not hold in general for networked control systems. This suggests that controller design needs to be substantially reconsidered for such systems. A second implication of our work is that controller design and communication protocol design are tightly coupled. This suggests that communication protocols targeted to networked control systems need to be developed. ■

APPENDIX PROOFS

A. UDP-Like Special Case: $R = 0$ and C Invertible

Without loss of generality we can assume $C = I$, since the linear transformation $z = Cx$ would give an equivalent system where the matrix C is the identity. Let us now consider the case when there is no measurement noise, i.e., $R = 0$. These assumptions mean that it is possible to measure the state x_k when the observation packet is delivered. In this case, the estimator (18)–(20) simplify as follows:

$$K_{k+1} = I \quad (43)$$

$$\begin{aligned} P_{k+1|k+1} &= (1 - \gamma_{k+1})P_{k+1|k} \\ &= (1 - \gamma_{k+1})(A'P_{k|k}A + Q \\ &\quad + \bar{\nu}(1 - \bar{\nu})Bu_k u_k' B') \end{aligned} \quad (44)$$

$$\begin{aligned} \mathbb{E}[P_{k+1|k+1} | \mathcal{G}_k] &= (1 - \bar{\gamma})(A'P_{k|k}A + Q \\ &\quad + \bar{\nu}(1 - \bar{\nu})Bu_k u_k' B') \end{aligned} \quad (45)$$

where in the last equation we used independence of γ_{k+1} and \mathcal{G}_k , and we used the fact that $P_{k|k}$ is a deterministic function of \mathcal{G}_k .

Following the same approach to optimal control adopted in Section V, we claim that the value function $V_k^*(x_k)$ can be written as follows:

$$V_k(x_k) = \hat{x}'_{k|k} S_k \hat{x}_{k|k} + \text{trace}(T_k P_{k|k}) + \text{trace}(D_k Q) \quad (46)$$

for $k = N, \dots, 0$. This is clearly true for $k = N$, in fact we have

$$\begin{aligned} V_N(x_N) &= \mathbb{E}[x_N' W_N x_N | \mathcal{G}_N] \\ &= \hat{x}'_{N|N} W_N \hat{x}_{N|N} + \text{trace}(W_N P_{N|N}) \end{aligned}$$

where we used Lemma 4.1(b), therefore, the statement is satisfied by $S_N = W_N$, $T_N = W_N$, $D_N = 0$. Note that (46) can be rewritten as follows:

$$V_k(x_k) = \mathbb{E}[x_k' S_k x_k | \mathcal{G}_k] + \text{trace}((T_k - S_k)P_{k|k}) + \text{trace}(D_k Q)$$

where we used once again Lemma 4.1(b). Moreover, to simplify notation we define $H_k \triangleq (T_k - S_k)$. Let us suppose that (46) is true for $k + 1$ and let us show by induction it holds true for k

$$\begin{aligned} V_k(x_k) &= \min_{u_k} \mathbb{E}[x_k' W_k x_k + \nu_k u_k' U_k u_k + V_{k+1}(x_{k+1}) | \mathcal{G}_k] \\ &= \min_{u_k} \left(\mathbb{E}[x_k' W_k x_k + \nu_k u_k' U_k u_k + x_{k+1}' S_{k+1} x_{k+1} \right. \\ &\quad \left. + \text{trace}(H_{k+1} P_{k+1|k+1}) \right. \\ &\quad \left. + \text{trace}(D_{k+1} Q) | \mathcal{G}_k \right] \\ &= \mathbb{E}[x_k' (W_k + A' S_{k+1} A) x_k | \mathcal{G}_k] \\ &\quad + \text{trace}(S_{k+1} Q) + (1 - \bar{\gamma}) \\ &\quad \times \text{trace}(H_{k+1} (A' P_{k|k} A + Q)) + \text{trace}(D_{k+1} Q) \\ &\quad + \min_{u_k} (\bar{\nu} u_k' U_k u_k + \bar{\nu} u_k' B' S_{k+1} B u_k \\ &\quad + 2\bar{\nu} u_k' B' S_{k+1} A \hat{x}_{k|k} + \bar{\nu}(1 - \bar{\nu})(1 - \bar{\gamma}) \\ &\quad \times \text{trace}(H_{k+1} B u_k u_k' B')) \\ &= \mathbb{E}[x_k' (W_k + A' S_{k+1} A) x_k | \mathcal{G}_k] \\ &\quad + \text{trace}((D_{k+1} + (1 - \bar{\gamma})H_{k+1})Q) \\ &\quad + (1 - \bar{\gamma})\text{trace}(A H_{k+1} A' P_{k|k}) + \text{trace}(S_{k+1} Q) \\ &\quad + \bar{\nu} \min_{u_k} (u_k' (U_k + B' (S_{k+1} + (1 - \bar{\nu}) \\ &\quad \times (1 - \bar{\gamma})H_{k+1}) B) \\ &\quad \times u_k + 2u_k' B' S_{k+1} A \hat{x}_{k|k}) \\ &= \hat{x}'_{k|k} (W_k + A' S_{k+1} A) \hat{x}_{k|k} \\ &\quad + \text{trace}((D_{k+1} + (1 - \bar{\gamma})T_{k+1} + \bar{\gamma}S_{k+1})Q) \\ &\quad + \text{trace}((W_k + \bar{\gamma}A' S_{k+1} A + (1 - \bar{\gamma})A T_{k+1} A') P_{k|k}) \\ &\quad + \bar{\nu} \min_{u_k} (u_k' (U_k + B' ((1 - \bar{\alpha})S_{k+1} + \bar{\alpha}T_{k+1}) B) u_k \\ &\quad + 2u_k' B' S_{k+1} A \hat{x}_{k|k}), \end{aligned}$$

where we defined $\bar{\alpha} = (1 - \bar{\nu})(1 - \bar{\gamma})$, we used Lemma 4.1(c) to get the second equality, and (8) and (45) to get the last equality. Since the quantity inside the outer parenthesis is a convex quadratic function, the minimizer is the solution of $\partial V_k / \partial u_k = 0$ which is given by

$$u_k^* = -(U_k + B'((1 - \bar{\alpha})S_{k+1} + \bar{\alpha}T_{k+1})B)^{-1} \times B' S_{k+1} A \hat{x}_{k|k} \quad (47)$$

$$= L_k \hat{x}_{k|k} \quad (48)$$

which is linear function of the estimated state $\hat{x}_{k|k}$. Substituting back into the value function we get

$$\begin{aligned} V_k(x_k) &= \hat{x}'_{k|k}(W_k + A'S_{k+1}A)\hat{x}_{k|k} \\ &\quad + \text{trace}((D_{k+1} + (1 - \bar{\gamma})T_{k+1} + \bar{\gamma}S_{k+1})Q) \\ &\quad + \text{trace}((W_k + A'S_{k+1}A + (1 - \bar{\gamma})AT_{k+1}A')P_{k|k}) \\ &\quad - \bar{\nu}\hat{x}'_{k|k}A'S_{k+1}BL_k\hat{x}_{k|k} \\ &= \hat{x}'_{k|k}(W_k + \bar{\gamma}A'S_{k+1}A - \bar{\nu}\hat{x}'_{k|k}A'S_{k+1}BL_k)\hat{x}_{k|k} \\ &\quad + \text{trace}((D_{k+1} + (1 - \bar{\gamma})T_{k+1} + \bar{\gamma}S_{k+1})Q) \\ &\quad + \text{trace}((W_k + A'S_{k+1}A + (1 - \bar{\gamma})AT_{k+1}A')P_{k|k}) \end{aligned}$$

where we used Lemma 4.1(b) in the last equality. From the last equation we see that the value function can be written as in (46) if and only if the following equations are satisfied:

$$\begin{aligned} S_k &= A'S_{k+1}A + W_k - \bar{\nu}A'S_{k+1}B \\ &\quad \times (U_k + B'((1 - \bar{\alpha})S_{k+1} + \bar{\alpha}T_{k+1})B)^{-1}B'S_{k+1}A \\ &= \Phi^S(S_{k+1}, T_{k+1}) \end{aligned} \quad (49)$$

$$\begin{aligned} T_k &= (1 - \bar{\gamma})A'T_{k+1}A + \bar{\gamma}A'S_{k+1}A + W_k \\ &= \Phi^T(S_{k+1}, T_{k+1}) \end{aligned} \quad (50)$$

$$D_k = (1 - \bar{\gamma})T_{k+1} + \bar{\gamma}S_{k+1} + D_{k+1}. \quad (51)$$

The optimal minimal cost for the finite horizon, $J_N^* = V_0(x_0)$ is then given by

$$\begin{aligned} J_N^* &= \bar{x}'_0 S_0 \bar{x}_0 + \text{trace}(S_0 P_0) \\ &\quad + \sum_{k=1}^N \text{trace}(((1 - \bar{\gamma})T_k + \bar{\gamma}S_k)Q). \end{aligned} \quad (52)$$

For the infinite horizon optimal controller, necessary and sufficient conditions for the average minimal cost $J_\infty \triangleq \lim_{N \rightarrow +\infty} (1/N)J_N^*$ to be finite, are that the coupled iterative (49) and (50) should converge to a finite value S_∞ and T_∞ as $N \rightarrow +\infty$. In the work of Imer et al. [36], similar equations were derived for the optimal LQG control under UDP with the additional more stringent conditions $Q = 0$ and B square and invertible. They determine necessary and sufficient conditions for those equations to converge. However, these conditions are invalid in the general case when B is not square. Below we prove a number of lemmas and theorems that will allow us to derive stronger necessary and sufficient conditions even when B is not necessarily square and invertible.

Lemma 8.1: Let $S, T \in \mathbb{M} = \{M \in \mathbb{R}^{n \times n} | M \geq 0\}$. Consider the operators $\Phi^S(S, T)$, and $\Phi^T(S, T)$ as defined in (49)

and (50), and consider the sequences $S_{k+1} = \Phi^S(S_k, T_k)$ and $T_{k+1} = \Phi^T(S_k, T_k)$. Consider $L_{S,T}^* = -(U + B'((1 - \bar{\alpha})S + \bar{\alpha}T)B)^{-1}B'SA$ and the operator:

$$\begin{aligned} \Upsilon(S, T, L) &= \left(1 - \frac{\bar{\nu}}{1 - \bar{\alpha}}\right)A'SA + W \\ &\quad + \frac{\bar{\nu}}{1 - \bar{\alpha}}(A + (1 - \bar{\alpha})BL)'S(A + (1 - \bar{\alpha})BL) \\ &\quad + \bar{\nu}L'UL + \bar{\nu}\bar{\alpha}L'B'TBL \end{aligned}$$

Then the following facts are true:

- $\Phi^S(S, T) = \min_L \Upsilon(S, T, L)$
- $0 \leq \Upsilon(S, T, L_{S,T}^*) = \Phi^S(S, T) \leq \Upsilon(S, T, L) \forall L$
- If $S_{k+1} > S_k$ and $T_{k+1} > T_k$, then $S_{k+2} > S_{k+1}$ and $T_{k+2} > T_{k+1}$.
- If the pair $(A, W^{1/2})$ is observable and $S = \Phi^S(S, T)$ and $T = \Phi^T(S, T)$, then $S > 0$ and $T > 0$.

Proof:

- If U is invertible then it is easy to verify by direct substitution that

$$\begin{aligned} \Upsilon(S, T, L) &= \Phi^S(S, T) + \bar{\nu}(L - L_{S,T}^*)' \\ &\quad \times (U + B'((1 - \bar{\alpha})S + \bar{\alpha}T)B)(L - L_{S,T}^*) \\ &\geq \Phi^S(S, T) \end{aligned}$$

- The nonnegativeness follows from the observation that $\Upsilon(S, T, L)$ is a sum of positive semi-definite matrices. In fact, $(1 - (\bar{\nu}/(1 - \bar{\alpha}))) = (\bar{\gamma}(1 - \bar{\nu})/(\bar{\nu} + \bar{\gamma}(1 - \bar{\nu}))) \geq 0$ and $0 \leq \bar{\alpha} \leq 1$. The equality $\Upsilon(S, T, L_{S,T}^*) = \Phi^S(S, T)$ can be verified by direct substitution. The last inequality follows directly from Fact (b).

c)

$$\begin{aligned} S_{k+2} &= \Phi^S(S_{k+1}, T_{k+1}) = \Upsilon(S_{k+1}, T_{k+1}, L_{S_{k+1}, T_{k+1}}^*) \\ &\geq \Upsilon(S_k, T_k, L_{S_{k+1}, T_{k+1}}^*) \geq \Upsilon(S_k, T_k, L_{S_k, T_k}^*) \\ &= \Phi^S(S_k, T_k) = S_{k+1} \\ T_{k+2} &= \Phi^T(S_{k+1}, T_{k+1}) \geq \Phi^T(S_k, T_k) = T_{k+1} \end{aligned}$$

- First observe that $S = \Phi^S(S, T) \geq 0$ and $T = \Phi^T(S, T) \geq 0$. Thus, to prove that $S, T > 0$, we only need to establish that S, T are nonsingular. Suppose they are singular, then there exist vectors $0 \neq v_s \in \mathcal{N}(S)$ and $0 \neq v_t \in \mathcal{N}(T)$, i.e., $Sv_s = 0$

and $Tv_t = 0$, where $\mathcal{N}(\cdot)$ indicates the null space. Then

$$\begin{aligned} 0 &= v_s' S v_s = v_s' \Phi^S(S, T) v_s = v_s' \Upsilon(S, T, L_{S,T}^*) v_s \\ &= \left(1 - \frac{\bar{\nu}}{1 - \bar{\alpha}}\right) v_s' A' S A v_s + v_s' W v_s + \star \end{aligned}$$

where \star indicates other terms. Since all the terms are positive semi-definite matrices, this implies that all the term must be zero

$$\begin{aligned} v_s' A' S A v_s = 0 &\implies S A v_s = 0 \implies A v_s \in \mathcal{N}(S) \\ v_s' W v_s = 0 &\implies W^{1/2} v_s = 0. \end{aligned}$$

As a result, the null space $\mathcal{N}(S)$ is A -invariant. Therefore, $\mathcal{N}(S)$ contains an eigenvector of A , i.e., there exists $u \neq 0$ such that $Su = 0$ and $Au = \sigma u$. As before, we conclude that $Wu = 0$. This implies (using the PBH test) that the pair $(A, W^{1/2})$ is not observable, contradicting the hypothesis. Thus, $\mathcal{N}(S)$ is empty, proving that $S > 0$. The same argument can be used to prove that also $T > 0$. ■

Lemma 8.2: Consider the following operator:

$$\begin{aligned} \Upsilon(S, T, L) &= A' S A + W + 2\bar{\nu} A' S B L \\ &\quad + \bar{\nu} L' (U + B'((1 - \bar{\alpha})S + \bar{\alpha}T)B)L. \end{aligned} \quad (53)$$

Assume that the pairs $(A, W^{1/2})$ and (A, B) are observable and controllable, respectively. Then the following statements are equivalent:

- a) There exist a matrix \tilde{L} and positive definite matrices \tilde{S} and \tilde{T} such that

$$\tilde{S} > 0, \quad \tilde{T} > 0, \quad \tilde{S} = \Upsilon(\tilde{S}, \tilde{T}, \tilde{L}), \quad \tilde{T} = \Phi^T(\tilde{S}, \tilde{T}).$$

- b) Consider the sequences

$$S_{k+1} = \Phi^S(S_k, T_k), \quad T_{k+1} = \Phi^T(S_k, T_k)$$

where the operators $\Phi^S(\cdot)$, $\Phi^T(\cdot)$ are defined in (49) and (50). For any initial condition $S_0, T_0 \geq 0$ we have

$$\lim_{k \rightarrow \infty} S_k = S_\infty, \quad \lim_{k \rightarrow \infty} T_k = T_\infty$$

and $S_\infty, T_\infty > 0$ are the unique positive definite solution of the following equations

$$S_\infty = \Phi^S(S_\infty, T_\infty), \quad T_\infty = \Phi^T(S_\infty, T_\infty).$$

Proof:

(a) \implies (b) The main idea of the proof consists in proving convergence of several monotonic sequences. Consider the sequences $V_{k+1} = \Upsilon(V_k, Z_k, \tilde{L})$ and $Z_{k+1} = \Phi^T(V_k, Z_k)$ with initial conditions $V_0 = Z_0 = 0$. It is easy to verify by substitution that $V_1 = W + \bar{\nu} \tilde{L}' U \tilde{L} \geq 0 = V_0$ and $Z_1 = W \geq 0 = Z_0$. Lemma 8.1(a) shows that the operator $\Upsilon(V, Z, \tilde{L})$ is linear and monotonically increasing in V and Z , i.e., $(V_{k+1} \geq V_k, Z_{k+1} \geq Z_k) \implies (V_{k+2} \geq V_{k+1}, Z_{k+2} \geq Z_{k+1})$. Also the operator $\Phi^T(V, Z)$ is linear and monotonically increasing in V and Z . Since $V_1 \geq V_0$ and $Z_1 \geq Z_0$, using an induction argument we have that $V_{k+1} \geq V_k, Z_{k+1} \geq Z_k$ for all time k , i.e., the sequences are monotonically increasing. These sequences are also bounded, in fact $(V_0 \leq \tilde{S}), (Z_0 \leq \tilde{T}) \implies (V_1 = \Upsilon(0, 0, \tilde{L}) \leq \Upsilon(\tilde{S}, \tilde{T}, \tilde{L}) = \tilde{S}), (Z_1 = \Phi^T(0, 0) \leq \Phi^T(\tilde{S}, \tilde{T}) = \tilde{T})$ and the same argument can be inductively used to show that $V_k \leq \tilde{S}$ and $Z_k \leq \tilde{T}$ for all k . Consider now the sequences S_k, T_k as defined in the theorem initialized with $S_0 = T_0 = 0$. By direct substitution we find that $S_1 = W \geq 0 = S_0$ and $T_1 = W \geq 0 = T_0$. By Lemma 8.1(c) follows that the sequences S_k, T_k are monotonically increasing. Moreover, by Lemma 8.1(b) it follows that $(S_k \leq V_k, T_k \leq Z_k) \implies (S_{k+1} = \Phi^S(S_k, T_k) \leq \Upsilon(S_k, T_k, \tilde{L}) \leq \Upsilon(V_k, Z_k, \tilde{L}) = V_{k+1}), (T_{k+1} = \Phi^T(S_k, T_k) \leq \Phi^T(V_k, Z_k) = Z_{k+1})$. Since this is verified for $k = 0$, it inductively follows that $(S_k \leq V_k, T_k \leq Z_k)$ for all k . Finally since V_k, Z_k are bounded, we have that $(S_k \leq \tilde{S}, T_k \leq \tilde{T})$. Since S_k, T_k are monotonically increasing and bounded, it follows that $\lim_{k \rightarrow \infty} S_k = S_\infty$ and $\lim_{k \rightarrow \infty} T_k = T_\infty$, where S_∞, T_∞ are semi-definite matrices. From this it easily follows that these matrices have the property $S_\infty = \Phi^S(S_\infty, T_\infty), T_\infty = \Phi^T(S_\infty, T_\infty)$. Definite positiveness of S_∞ follows from Lemma 8.1(d) using the hypothesis that $(A, W^{1/2})$ is observable. The same argument can be used to prove that $T_\infty > 0$. Finally proof of uniqueness of solution and convergence for all initial conditions S_0, T_0 can be obtained similarly to Theorem 1 in [37] and it is, therefore, omitted.

(b) \implies (a) This part follows easily by choosing $\tilde{L} = L_{S_\infty, T_\infty}^*$, where $L_{S,T}^*$ is defined in Lemma 8.1. Using Lemma 8.1(b) we have $S_\infty = \Phi^S(S_\infty, T_\infty) = \Upsilon(S_\infty, T_\infty, \tilde{L})$, therefore, the statement is verified using $\tilde{S} = S_\infty$ and $\tilde{T} = T_\infty$. ■

Lemma 8.3: Let us consider the fixed points of (49) and (50), i.e., $S = \Phi^S(S, T), T = \Phi^T(S, T)$ where $S, T \geq 0$. Let

A be unstable. A necessary condition for existence of solution is

$$|A|^2(\bar{\gamma} + \bar{\nu} - 2\bar{\gamma}\bar{\nu}) < \bar{\gamma} + \bar{\nu} - \bar{\gamma}\bar{\nu} \quad (54)$$

where $|A| \triangleq \max_i |\lambda_i(A)|$ is the largest eigenvalue of the matrix A .

Proof: To prove the necessity condition it is sufficient to show that there exist some initial conditions $S_0, T_0 \geq 0$ for which the sequences $S_{k+1} = \Phi^S(S_k, T_k)$, $T_{k+1} = \Phi^T(S_k, T_k)$ are unbounded, i.e., $\lim_{k \rightarrow \infty} S_k = \lim_{k \rightarrow \infty} T_k = \infty$. To do so, suppose that at some time-step k we have

A necessary condition for stability is $|A|^2(\bar{\gamma} + \bar{\nu} - 2\bar{\gamma}\bar{\nu}) < (\bar{\gamma} + \bar{\nu} - \bar{\gamma}\bar{\nu})$.

$S_k \geq s_k vv'$ and $T_k \geq t_k vv'$, where $s_k, t_k > 0$, and v is the eigenvector corresponding to the largest eigenvalue of A' , i.e., $Av' = \lambda_{\max} v$ and $|\lambda_{\max}| = |A'| = |A|$. Then we have

$$\begin{aligned} S_{k+1} &= \Phi^S(S_k, T_k) \geq \Phi^S(s_k vv', t_k vv') \\ &= \min_L \Upsilon(s_k vv', t_k vv', L) \\ &= \min_L (s_k A' vv' A + W + 2s_k \bar{\nu} A' vv' BL \\ &\quad + \bar{\nu} L'(U + B'((1 - \bar{\alpha})s_k vv' + \bar{\alpha}t_k vv')B)L) \\ &\geq \min_L (s_k |A|^2 vv' + 2s_k \bar{\nu} \lambda_{\max} vv' BL \\ &\quad + \bar{\nu} L' B'((1 - \bar{\alpha})s_k vv' + \bar{\alpha}t_k vv')B)L) \\ &= \min_L \left(s_k |A|^2 vv' - \frac{|A|^2 \bar{\nu} s_k^2}{\xi_k} vv' \right. \\ &\quad \left. + \bar{\nu} \xi_k \left(\lambda_{\max} s_k^2 I + \frac{1}{\xi_k} BL \right)' vv' \right. \\ &\quad \left. \times \left(\lambda_{\max} s_k^2 I + \frac{1}{\xi_k} BL \right) \right) \\ &\geq s_k |A|^2 vv' - \frac{|A|^2 \bar{\nu} s_k^2}{(1 - \bar{\alpha})s_k + \bar{\alpha}t_k} vv' \\ &= |A|^2 s_k \left(1 - \frac{\bar{\nu} s_k}{(1 - \bar{\alpha})s_k + \bar{\alpha}t_k} \right) vv' \\ &= s_{k+1} vv' \end{aligned}$$

where I is the identity matrix and $\xi_k = (1 - \bar{\alpha})s_k + \bar{\alpha}t_k$. Similarly, we have

$$\begin{aligned} T_{k+1} &= \Phi^T(S_k, T_k) \geq \Phi^T(s_k vv', t_k vv') \\ &= (1 - \bar{\gamma})t_k A' vv' A + \bar{\gamma} s_k A' vv' A + W \\ &\geq (1 - \bar{\gamma})t_k |A|^2 vv' + \bar{\gamma} s_k |A|^2 vv' \\ &= |A|^2 ((1 - \bar{\gamma})t_k + \bar{\gamma} s_k) vv' \\ &= t_{k+1} vv'. \end{aligned}$$

We can summarize the previous results as follows:

$$\begin{aligned} (S_k \geq s_k vv', T_k \geq t_k vv') \\ \Rightarrow (S_{k+1} \geq s_{k+1} vv', T_{k+1} \geq t_{k+1} vv') \\ s_{k+1} = \phi^s(s_k, t_k) = |A|^2 s_k \left(1 - \frac{\bar{\nu} s_k}{(1 - \bar{\alpha})s_k + \bar{\alpha}t_k} \right) \\ t_{k+1} = \phi^t(s_k, t_k) = |A|^2 ((1 - \bar{\gamma})t_k + \bar{\gamma} s_k). \end{aligned}$$

Let us define the following sequences:

$$\begin{aligned} S_{k+1} &= \Phi^S(S_k, T_k), \quad T_{k+1} = \Phi^T(S_k, T_k), \quad S_0 = T_0 = vv' \\ s_{k+1} &= \phi^s(s_k, t_k), \quad t_{k+1} = \phi^t(s_k, t_k), \quad s_0 = t_0 = 1 \\ \tilde{S}_k &= s_k vv', \quad \tilde{T}_k = t_k vv'. \end{aligned}$$

From the previous derivations we have that $S_k \geq \tilde{S}_k$, $T_k \geq \tilde{T}_k$ for all time k . Therefore, it is sufficient to find when the scalar sequences s_k, t_k diverges to find the necessary conditions. It should be evident that also the operators $\phi^s(s, t)$, $\phi^t(s, t)$ are monotonic in their arguments. Also it should be evident that the only fixed points of $s = \phi^s(s, t)$, $t = \phi^t(s, t)$ are $s = t = 0$. Therefore, we should be find when the origin is an unstable equilibrium point, since in this case $\lim_{k \rightarrow \infty} s_k, t_k = \infty$. Note that $t = \phi^t(s, t)$ can be written as

$$\begin{aligned} t &= \Phi^T(s, t) = (1 - \bar{\gamma})|A|^2 t + \bar{\gamma}|A|^2 s \\ &= \psi(s) = \frac{\bar{\gamma}|A|^2 s}{1 - (1 - \bar{\gamma})|A|^2} \end{aligned}$$

with the additional constraint $1 - (1 - \bar{\gamma})|A|^2 > 0$. A necessary condition for stability for the origin is that the origin of

restricted map $z_{k+1} = \phi(z_k, \psi(z_k))$ is stable. The restricted map is given by

$$\begin{aligned} z_{k+1} &= |A|^2 z_k \left(1 - \bar{\nu} \frac{z_k}{(1 - \bar{\alpha})z_k + \bar{\alpha} \frac{\bar{\gamma}|A|^2}{1 - (1 - \bar{\gamma})|A|^2} z_k} \right) \\ &= |A|^2 \left(1 - \frac{\bar{\nu}}{(1 - \bar{\alpha}) + \bar{\alpha} \frac{\bar{\gamma}|A|^2}{1 - (1 - \bar{\gamma})|A|^2}} \right) z_k \\ &= |A|^2 \left(1 - \frac{\bar{\nu}(1 - (1 - \bar{\gamma})|A|^2)}{\bar{\gamma} + \bar{\nu} - \bar{\gamma}\bar{\nu} - \bar{\nu}(1 - \bar{\gamma})|A|^2} \right) z_k \\ &= \left(\frac{\bar{\gamma}(1 - \bar{\nu})|A|^2}{\bar{\gamma} + \bar{\nu} - \bar{\gamma}\bar{\nu} - \bar{\nu}(1 - \bar{\gamma})|A|^2} \right) z_k. \end{aligned}$$

This is a linear map and it is stable only if the term inside the parenthesis is smaller than unity, i.e.,

$$\begin{aligned} \left(\frac{\bar{\gamma}(1 - \bar{\nu})|A|^2}{\bar{\gamma} + \bar{\nu} - \bar{\gamma}\bar{\nu} - \bar{\nu}(1 - \bar{\gamma})|A|^2} \right) &< 1 \\ \bar{\gamma} + \bar{\nu} - \bar{\gamma}\bar{\nu} - \bar{\nu}(1 - \bar{\gamma})|A|^2 &> \bar{\gamma}(1 - \bar{\nu})|A|^2 \\ \bar{\gamma} + \bar{\nu} - \bar{\gamma}\bar{\nu} &> |A|^2(\bar{\gamma} + \bar{\nu} - 2\bar{\gamma}\bar{\nu}) \end{aligned}$$

which concludes the lemma. \blacksquare

Lemma 8.4: Let us consider the fixed points of (49) and (50), i.e., $S = \Phi^S(S, T)$, $T = \Phi^T(S, T)$ where $S, T \geq 0$. Let A be unstable, $(A, W^{1/2})$ observable and B square and invertible. Then a sufficient condition for existence of solution is

$$|A|^2(\bar{\gamma} + \bar{\nu} - 2\bar{\gamma}\bar{\nu}) < \bar{\gamma} + \bar{\nu} - \bar{\gamma}\bar{\nu} \quad (55)$$

where $|A| \triangleq \max_i |\lambda_i(A)|$ is the largest eigenvalue of the matrix A .

Proof: The proof is constructive. In fact, we find a control feedback gain \tilde{L} that satisfies the conditions stated in Theorem 8.2(a). Let $\tilde{L} = -\eta B^{-1}A$ where $\eta > 0$ is a positive scalar that is to be determined. Also consider $S = sI$, $T = tI$, where I is the identity matrix and $s, t > 0$ are positive scalars. Then, we have

$$\begin{aligned} \Upsilon(sI, tI, \tilde{L}) &= A'sA + W - 2\bar{\nu}\eta A'sA \\ &\quad + \bar{\nu}A'B^{-1}UB^{-1}A + \bar{\nu}\eta^2 A'((1 - \bar{\alpha})s + \bar{\alpha}t)A \\ &\leq |A|^2 (s - 2\bar{\nu}s\eta + \bar{\nu}((1 - \bar{\alpha})s + \bar{\alpha}t)\eta^2) I + wI \\ &= \varphi^s(s, t, \eta) I \end{aligned} \quad (56)$$

$$\begin{aligned} \Phi^T(sI, tI) &= \bar{\gamma}A'sA + (1 - \bar{\gamma})A'tA + W \\ &\leq (\bar{\gamma}|A|^2 s + (1 - \bar{\gamma})|A|^2 t) I + wI \\ &\leq \varphi^t(s, t) I \end{aligned} \quad (57)$$

where $w = |W + \bar{\nu}A'B^{-1}UB^{-1}A| > 0$ and I is the identity matrix. Let us consider the following scalar operators and sequences:

$$\varphi^s(s, t, \eta) = |A|^2 (1 - 2\bar{\nu}\eta + \bar{\nu}(1 - \bar{\alpha})\eta^2) s + \bar{\nu}\bar{\alpha}\eta^2 t + w$$

$$\varphi^t(s, t) = \bar{\gamma}|A|^2 s + (1 - \bar{\gamma})|A|^2 t + w$$

$$s_{k+1} = \varphi^s(s_k, t_k, \eta), \quad t_{k+1} = \varphi^t(s_k, t_k), \quad s_0 = t_0 = 0.$$

The operators are clearly monotonically increasing in s, t , and since $s_1 = \varphi^s(s_0, t_0, \eta) = w \geq s_0$ and $t_1 = \varphi^t(s_0, t_0) = w \geq t_0$, it follows that the sequences s_k, t_k are monotonically increasing. If these sequences are bounded, then they must converge to \tilde{s}, \tilde{t} . Therefore, s_k, t_k are bounded if and only if there exist $\tilde{s}, \tilde{t} > 0$ such that $\tilde{s} = \varphi^s(\tilde{s}, \tilde{t}, \eta)$ and $\tilde{t} = \varphi^t(\tilde{s}, \tilde{t})$. Let us find the fixed points

$$\begin{aligned} \tilde{t} &= \varphi^t(\tilde{s}, \tilde{t}) \Rightarrow \\ \tilde{t} &= \frac{\bar{\gamma}|A|^2}{1 - (1 - \bar{\gamma})|A|^2} \tilde{s} + w_t \end{aligned}$$

where $w_t \triangleq (w/(1 - (1 - \bar{\gamma})|A|^2)) > 0$, and we must have $1 - (1 - \bar{\gamma})|A|^2 > 0$ to guarantee that $\tilde{t} > 0$. Substituting back into the operator φ^s we have

$$\begin{aligned} \tilde{s} &= |A|^2 (1 - 2\bar{\nu}\eta + \bar{\nu}(1 - \bar{\alpha})\eta^2) \tilde{s} + \bar{\nu}\bar{\alpha}\eta^2 \frac{\bar{\gamma}|A|^2}{1 - (1 - \bar{\gamma})|A|^2} \tilde{s} \\ &\quad + \bar{\nu}\bar{\alpha}\eta^2 w_t + w \\ &= |A|^2 \left(1 - 2\bar{\nu}\eta + \bar{\nu} \right. \\ &\quad \times \left. \left((1 - \bar{\alpha}) + \frac{\bar{\gamma}\bar{\alpha}|A|^2}{1 - (1 - \bar{\gamma})|A|^2} \right) \eta^2 \right) \tilde{s} + w(\eta) \\ &= |A|^2 \left(1 - 2\bar{\nu}\eta \right. \\ &\quad \left. + \bar{\nu} \frac{\bar{\gamma} + \bar{\nu} - \bar{\gamma}\bar{\nu} - \bar{\nu}(1 - \bar{\gamma})|A|^2}{1 - (1 - \bar{\gamma})|A|^2} \eta^2 \right) \tilde{s} + w(\eta) \\ &= a(\eta) \tilde{s} + w(\eta) \end{aligned}$$

where $w(\eta) \triangleq \bar{\nu}\bar{\alpha}\eta^2 w_t + w > 0$. For a positive solution \tilde{s} to exist, we must have $a(\eta) < 1$. Since $a(\eta)$ is a quadratic function of the free parameter η , we can try to increase the basin of existence of solutions by

choosing $\eta^* = \arg \min_{\eta} a(\eta)$, which can be found by solving $(da/d\eta)(\eta^*) = 0$ and is given by

$$\eta^* = \frac{1 - (1 - \bar{\gamma})|A|^2}{\bar{\gamma} + \bar{\nu} - \bar{\gamma}\bar{\nu} - \bar{\nu}(1 - \bar{\gamma})|A|^2}.$$

Therefore, a sufficient condition for existence of solutions is given by

$$a(\eta^*) < 1$$

$$|A|^2 \left(1 - \bar{\nu} \frac{1 - (1 - \bar{\gamma})|A|^2}{\bar{\gamma} + \bar{\nu} - \bar{\gamma}\bar{\nu} - \bar{\nu}(1 - \bar{\gamma})|A|^2} \right) < 1$$

$$\left(\frac{\bar{\gamma}(1 - \bar{\nu})|A|^2}{\bar{\gamma} + \bar{\nu} - \bar{\gamma}\bar{\nu} - \bar{\nu}(1 - \bar{\gamma})|A|^2} \right) < 1$$

which is the same bound for the necessary condition of convergence in Lemma 8.3.

If this condition is satisfied, then $\lim_{k \rightarrow \infty} s_k = \tilde{s}$ and $\lim_{k \rightarrow \infty} t_k = \tilde{t}$. Let us consider now the sequences $\bar{S}_k = s_k I$, $\bar{T}_k = t_k I$, $S_{k+1} = \Upsilon(S_k, T_k, \bar{L})$, and $T_{k+1} = \Phi^T(S_k, T_k)$ where $\bar{L} = -\eta^* B^{-1}A$, $S_0 = T_0 = 0$, and s_k, t_k where defined above. These sequences are all monotonically increasing. From (56) and (57), it follows that $(S_k \leq s_k I, T_k \leq t_k I) \Rightarrow (S_{k+1} \leq s_{k+1} I, T_{k+1} \leq t_{k+1} I)$. Since this is verified for $k = 0$ we can claim that $S_k < \tilde{s}I$ and $T_k < \tilde{t}I$ for all k . Since S_k, T_k are monotonically increasing and bounded, then they must converge to positive semidefinite matrices $\tilde{S}, \tilde{T} \geq 0$ which solve the equations $\tilde{S} = \Upsilon(\tilde{S}, \tilde{T}, \bar{L})$ and $\tilde{T} = \Phi^T(\tilde{S}, \tilde{T})$. Since by hypothesis the pair $(A, W^{1/2})$ is observable, using similar arguments of Lemma 8.1(d), it is possible to show that $\tilde{S}, \tilde{T} > 0$. Therefore, $\tilde{S}, \tilde{T}, \bar{L}$ satisfy the conditions of Theorem 8.2(a), from which it follows statement (b) of the same theorem. This implies that the sufficient conditions derived here guarantee the claim of the lemma. ■

We can use the previous lemmas to prove the following theorems that states the properties of optimal control for UDP-like protocols in the special scenario with no measurement noise and full state observation.

Theorem 8.5: Consider the system (1)–(3) and consider the problem of minimizing the cost function (5) within the class of admissible policies $u_k = f(\mathcal{G}_k)$, where \mathcal{G}_k is the information available under UDP-like schemes, given in (4). Assume also that $R = 0$ and C is square and invertible. Then:

- The optimal estimator gain is constant and in particular $K_k = I$ if $C = I$.
- The infinite horizon optimal control exists if and only if there exists positive definite matrices $S_\infty, T_\infty > 0$ such that $S_\infty = \Phi^S(S_\infty, T_\infty)$ and $T_\infty = \Phi^T(S_\infty, T_\infty)$, where Φ^S and Φ^T are defined in (49) and (50).
- The infinite horizon optimal controller gain is constant

$$\lim_{k \rightarrow \infty} I_k = L_\infty$$

$$L_\infty = -(B'(\bar{\alpha}T_\infty + (1 - \bar{\alpha})S_\infty)B + U)^{-1} \times B'S_\infty A. \quad (58)$$

- A necessary condition for existence of $S_\infty, T_\infty > 0$ is

$$|A|^2(\bar{\gamma} + \bar{\nu} - 2\bar{\gamma}\bar{\nu}) < \bar{\gamma} + \bar{\nu} - \bar{\gamma}\bar{\nu} \quad (59)$$

where $|A| \triangleq \max_i |\lambda_i(A)|$ is the largest eigenvalue of the matrix A . This condition is also sufficient if B is square and invertible.

- The expected minimum cost for the infinite horizon scenario converges to

$$J_\infty^* = \lim_{k \rightarrow \infty} \frac{1}{N} J_N^*$$

$$= \text{trace}((1 - \bar{\gamma})T_\infty + \bar{\gamma}S_\infty)Q. \quad (60)$$

Proof: (a) This fact follows from (43)–(45). Statements (b), (c), and (e) follow from Lemma 8.2 and (47) and (52). Statement (d) corresponds to Lemmas 8.3 and 8.4. ■

REFERENCES

- I. A. W. Su, Y. Sankarasubramaniam, and E. Cayirci, "A survey on sensor networks," *IEEE Commun. Mag.*, vol. 40, no. 8, pp. 102–116, Aug. 2002.
- D. Estrin, D. Culler, K. Pister, and G. Sukhatme, "Connecting the physical world with pervasive networks," *IEEE Pervasive Computing*, vol. 1, no. 1, pp. 59–69, Jan. 2002.
- Proc. IEEE (Special Issue on Sensor Networks and Applications)*, vol. 91, no. 8, pp. 1151–1256, Aug. 2003.
- J. Wills, "Will HVAC control go wireless?" *ASHRAE J.*, vol. 46, no. 7, pp. 46–50, Jul. 2004.
- M. Kintner-Meyer and R. Conant, "Opportunities of wireless sensors and controls for building operation," *Energ. Eng. J.*, vol. 102, no. 5, pp. 27–48, 2005.
- B. Warneke, M. Last, B. Leibowitz, and K. Pister, "Smart dust: Communicating with a cubic-millimeter computer," *Computer*, vol. 34, no. 1, pp. 44–51, Jan. 2001.
- S. Boyer, *SCADA: Supervisory Control and Data Acquisition*, ISA-The Instrumentation, Systems, and Automation Society 2004.
- D. Bailey, *Practical SCADA for Industry*. Burlington, MA: Newnes, 2003.
- A. L. Sangiovanni-Vincentelli, "Electronic-system design in the automobile industry," *IEEE Microw. Mag.*, vol. 21, no. 3, pp. 8–18, May 2003.
- G. Leen and D. Heffernan, "Expanding automotive electronic systems," *Computer*, vol. 35, no. 1, pp. 88–93, 2002.

- [11] V. Gupta, D. Spanos, B. Hassibi, and R. M. Murray, "Optimal LQG control across a packet-dropping link," *Systems Control Lett.* 2005.
- [12] Y. Xu and J. Hespanha, "Estimation under controlled and uncontrolled communications in networked control systems," in *Proc. IEEE Conf. Decision and Control*, Sevilla, Spain, Dec. 2005, pp. 842–847.
- [13] S. Smith and P. Seiler, "Estimation with lossy measurements: Jump estimators for jump systems," *IEEE Trans. Autom. Control*, vol. 48, no. 12, pp. 1453–1464, Dec. 2003.
- [14] J. Nilsson, B. Bernhardsson, and B. Wittenmark, "Stochastic analysis and control of real-time systems with random time delays," *Automatica*, vol. 34, no. 1, pp. 57–64, Jan. 1998.
- [15] J. Nilsson, "Real-time control systems with delays," Ph.D. dissertation, Dept. Automatic Control, Lund Inst. Technol., Lund, Sweden, 1998.
- [16] C. N. Hadjicostis and R. Touri, "Feedback control utilizing packet dropping network links," in *Proc. IEEE Conf. Decision and Control*, Las Vegas, NV, Dec. 2002, vol. 2, pp. 1205–1210.
- [17] Q. Ling and M. Lemmon, "Optimal dropout compensation in networked control systems," presented at the IEEE Conf. Decision and Control, Maui, HI, Dec. 2003.
- [18] N. Yu, L. Wang, G. Xie, and T. Chu, "Stabilization of networked control systems with data packet dropout via swithed system approach," in *IEEE Int. Symp. Computer Aided Control Systems Design*, Taipei, Taiwan, Sep. 2004, pp. 362–367.
- [19] P. Seiler and R. Sengupta, "An H_∞ approach to networked control," *IEEE Trans. Autom. Control*, vol. 50, no. 3, pp. 356–364, Mar. 2005.
- [20] A. V. Savkin and I. R. Petersen, "Robust filtering with missing data and a deterministic description of noise and uncertainty," *Int. J. Syst. Sci.*, vol. 28, no. 4, pp. 373–390, 1997.
- [21] J. do Val, J. Geromel, and O. Costa, "Solutions for the linear quadratic control problem of markov jump linear systems," *J. Optimization Theory Appl.*, vol. 103, no. 2, pp. 283–311, 1999.
- [22] O. Costa, "Stationary filter for linear minimum mean square error estimator of discrete-time markovian jump systems," *Trans. Autom. Control*, vol. 48, no. 8, pp. 1351–1356, Aug. 2002.
- [23] Z. Wang, D. Ho, and X. Liu, "Variance-constrained control for uncertain stochastic systems with missing measurements," *IEEE Trans. Syst., Man, Cybern. A: Syst. Humans*, vol. 35, no. 5, pp. 746–753, Sep. 2005.
- [24] N. Elia and J. Eisembeis, "Limitation of linear control over packet drop networks," in *Proc. IEEE Conf. Decision and Control*, Bahamas, Dec. 2004, vol. 5, pp. 5152–5157.
- [25] N. Elia, "Remote stabilization over fading channels," *Syst. Control Lett.*, vol. 54, pp. 237–249, 2005.
- [26] W. S. Wong and R. W. Brockett, "Systems with finite communication bandwidth constraints. II. Stabilization with limited information feedback," *IEEE Trans. Autom. Contr.*, vol. 44, no. 5, pp. 1049–1053, May 1999.
- [27] N. Elia and S. Mitter, "Stabilization of linear systems with limited information," *IEEE Trans. Autom. Contr.*, vol. 46, no. 9, pp. 1384–1400, Sep. 2001.
- [28] J. P. Hespanha, A. Ortega, and L. Vasudevan, "Towards the control of linear systems with minimum bit-rate," in *Proc. Int. Symp. Mathematical Theory of Networks and Systems*, 2002, pp. 1–15.
- [29] G. N. Nair and R. J. Evans, "Exponential stabilisability of finite dimensional linear systems with limited data rates," *Automatica*, vol. 39, no. 4, pp. 585–593, Apr. 2003.
- [30] S. Tatikonda and S. Mitter, "Control under communication constraints," *IEEE Trans. Autom. Contr.*, vol. 49, no. 7, pp. 1056–1068, Jul. 2004.
- [31] J. H. Braslavsky, R. H. Middleton, and J. S. Freudenberg, "Feedback stabilization over signal-to-noise ratio constrained channels," in *Proc. 2004 American Control Conf.*, Jun. 2004, pp. 4903–4908.
- [32] N. Martins, M. Dahleh, and N. Elia, "Feedback stabilization of uncertain systems using a stochastic digital link," in *Proc. IEEE Conf. Decision and Control*, Dec. 2004, vol. 2, pp. 1889–1895.
- [33] S. Yuksel and T. Basar, "Minimum rate coding for state estimation over noiseless channels," in *Proc. IEEE Conf. Decision and Control*, 2004, pp. 4503–4508.
- [34] D. Liberzon and J. P. Hespanha, "Stabilization of nonlinear systems with limited information feedback," *IEEE Trans. Autom. Contr.*, vol. 50, no. 6, pp. 910–915, Jun. 2005.
- [35] A. Sahai and S. Mitter, "The necessity and sufficiency of anytime capacity for control over a noisy communication link: Part I scalar systems," *IEEE Trans. Inf. Theory*, vol. 52, no. 8, pp. 3369–3395, Aug. 2006.
- [36] O. C. Imer, S. Yuksel, and T. Basar, "Optimal control of dynamical systems over unreliable communication links," *Automatica*, vol. 42, no. 9, pp. 1429–1439, Sep. 2006.
- [37] B. Sinopoli, L. Schenato, M. Franceschetti, K. Poolla, M. Jordan, and S. Sastry, "Kalman filtering with intermittent observations," *IEEE Trans. Autom. Contr.*, vol. 49, no. 9, pp. 1453–1464, Sep. 2004.
- [38] X. Liu and A. Goldsmith, "Kalman filtering with partial observation losses," in *Proc. IEEE Conf. Decision and Control*, Bahamas, Dec. 2004, vol. 4, pp. 4180–4186.
- [39] B. Sinopoli, L. Schenato, M. Franceschetti, K. Poolla, M. Jordan, and S. Sastry, "Optimal control with unreliable communication: The TCP case," in *Proc. American Control Conf.*, Portland, OR, Jun. 2005, vol. 5, pp. 3354–3359.
- [40] D. Bertsekas and J. Tsitsiklis, *Neuro-Dynamic Programming*. Nashua, NH: Athena Scientific, Sep. 1996.
- [41] G. Chen, G. Chen, and S. Hsu, *Linear Stochastic Control Systems*. Boca Raton, FL: CRC Press, 1995.
- [42] T. Katayama, "On the matrix Riccati equation for linear systems with a random gain," *IEEE Trans. Autom. Control*, vol. AC-21, no. 2, pp. 770–771, Oct. 1976.
- [43] W. Koning, "Infinite horizon optimal control for linear discrete time systems with stochastic parameters," *Automatica*, vol. 18, no. 4, pp. 443–453, 1982.
- [44] M. Zhang and T.-J. Tarn, "Hybrid control of the pendubot," *IEEE/ASME Trans. Mechatron.*, vol. 7, no. 1, pp. 79–86, 2002.
- [45] B. Sinopoli, L. Schenato, M. Franceschetti, K. Poolla, M. Jordan, and S. Sastry, "Optimal linear LQG control over lossy networks without packet acknowledgment," presented at the IEEE Conf. Decision and Control, San Diego, CA, Dec. 2006.

ABOUT THE AUTHORS

Luca Schenato (Member, IEEE) received the Dr. Eng. degree in electrical engineering from the University of Padova, Padova, Italy, in 1998 and the Ph.D. degree in electrical engineering and computer sciences from the University of California at Berkeley (U.C. Berkeley), in 2003.

From January 2004 till August 2004, he was a postdoctoral scholar at U.C. Berkeley. Since then he has been with the Control Systems Group in the Department of Information Engineering at the University of Padova where he is Adjunct Professor. His interests include networked control systems, wireless sensor networks, distributed control, swarm robotics, and biomimetic locomotion.

Dr. Schenato was awarded the 2004 Researchers Mobility Fellowship by the Italian Ministry of Education, University and Research (MIUR), and, jointly with Dr. B. Sinopoli, the 2006 Eli Jury Award at U.C. Berkeley for outstanding research achievement in the area of systems, communications, control, and signal processing.



Bruno Sinopoli (Member, IEEE) received the Dr. Eng. degree from the University of Padova, Padova, Italy, in 1998. He received the M.S. and Ph.D. degrees in electrical engineering from the University of California at Berkeley (U.C. Berkeley), in 2003 and 2005, respectively.

He currently holds a joint postdoctoral appointment in the departments of Electrical Engineering both at Stanford University, Stanford, CA, and at the U.C. Berkeley. His research interests include networked embedded control systems, distributed estimation and control, and hybrid systems with applications to wireless sensor-actuator networks.

Dr. Sinopoli was awarded, jointly with Dr. L. Schenato, the 2006 Eli Jury Award for outstanding research achievement in the areas of systems, communications, control and signal processing at U.C. Berkeley.



Massimo Franceschetti (Member, IEEE) received the Laurea degree (*magna cum laude*) in computer engineering from the University of Naples, Naples, Italy, in 1997, and the M.S. and Ph.D. degrees in electrical engineering from the California Institute of Technology, Pasadena, in 1999 and 2003.

He is an Assistant Professor in the Department of Electrical and Computer Engineering, University of California at San Diego. Before joining UCSD, he was a postdoctoral scholar at University of California at Berkeley for two years. He has held visiting positions at the Vrije Universiteit Amsterdam in the Netherlands, the Ecole Polytechnique Federale de Lausanne in Switzerland, and the University of Trento in Italy. His research interests include random networks for communication, wave propagation in random media, and control over networks. He is currently associate guest co-editor of the IEEE TRANSACTIONS ON INFORMATION THEORY, special issue on relay and cooperation in networks.

Prof. Franceschetti was awarded the C.H. Wilts Prize in 2003 for best doctoral thesis in Electrical Engineering at Caltech; the S.A. Schelkunoff award in 2005 (jointly with Prof. J. Bruck and Prof. L. J. Shulman) for best paper in the IEEE TRANSACTIONS ON ANTENNAS AND PROPAGATION; and an NSF CAREER award in 2006.

Kameshwar Poolla received the Bachelor of Technology degree from the Indian Institute of Technology, Bombay, India, in 1980, and the Ph.D. degree from the University of Florida, Gainesville in 1984.

He has served on the faculty of the Department of Electrical and Computer Engineering at the University of Illinois, Urbana, from 1984 to 1991. Since then, he has been with the University of California, Berkeley, where he is a Professor of Mechanical Engineering and Electrical Engineering & Computer Sciences. He has also held visiting appointments at Honeywell, McGill University, M.I.T., Michigan, and Columbia, and has worked as a Field Engineer with Schlumberger on oilrigs in West Africa. In 1999, he co-founded On Wafer Technologies which offers metrology-based yield-enhancement solutions for the semiconductor industry, where he currently serves as Chief Scientist. His research interests include micro-sensors, system identification, robust control, semiconductor manufacturing, and medical imaging.

Prof. Poolla was awarded a 1988 NSF Presidential Young Investigator Award, the 1993 Hugo Schuck Best Paper Prize, the 1994 Donald P. Eckman Award, the 1998 Distinguished Teaching Award of the University of California, and the 2005 IEEE TRANSACTIONS ON SEMICONDUCTOR MANUFACTURING Best Paper Prize.



S. Shankar Sastry (Fellow, IEEE) received the M.S. degree (*honoris causa*) from Harvard University, Cambridge, MA, in 1994, and the Ph.D. degree from the University of California, Berkeley, in 1981.

From 1980 to 1982, he was an Assistant Professor at Massachusetts Institute of Technology, Cambridge. In 2000, he was Director of the Information Technology Office at the Defense Advanced Research Projects Agency, Arlington, VA, and Chairman of the Department of Electrical Engineering and Computer Sciences, University of California, Berkeley. He is currently the NEC Distinguished Professor of Electrical Engineering and Computer Sciences and Bioengineering, and the Director of the Center for Information Technology Research in the Interest of Society, University of California, Berkeley.

His research interests are embedded and autonomous software, computer vision, computation in novel substrates such as DNA, nonlinear and adaptive control, robotic telesurgery, control of hybrid systems, embedded systems, sensor networks, and biological motor control.

Dr. Sastry was elected into the National Academy of Engineering in 2000 "for pioneering contributions to the design of hybrid and embedded systems." He has served as Associate Editor for IEEE TRANSACTIONS ON AUTOMATIC CONTROL, IEEE Control Systems Magazine, and IEEE TRANSACTIONS ON CIRCUITS AND SYSTEMS.

